



P&PE
PUMPS & PROCESS EQUIPMENT INC.

To Request a Quote,
CALL US 1-847-882-8116

OPERATION – ASSEMBLY INSTRUCTIONS AND PARTS LIST FOR “L10” DRIVE END (FRAME SIZES 1L10, 2L10, 3L10, 1L10H, 2L10H, 3M8, 3P6, 6P6, 9P6)

GENERAL

The Moyno® Pump is one of the most versatile pumps available. It has been proven in thousands of applications over the past 50 years. It is backed by the experience gained over the years, both in application and manufacturing know-how.

The Moyno progressing cavity pump is a single-screw rotary pump. The pumping action is created by the single helical rotor rolling eccentrically in the double threaded helix of the stator. In its revolution, the rotor forms in conjunction with the stator a series of sealed cavities 180 degrees apart. As the rotor turns the cavities progress from the suction to the discharge. As one cavity diminishes, the opposing cavity is increasing at exactly the same rate. Thus, the sum of the two discharges is a constant volume. The result is a pulsation-less positive displacement flow with no valves.

WARNING

1. Enclose all rotating belts, pulleys, drive shafts, etc., to comply with acceptable industry safety standards for rotating equipment. Failure to comply could result in personal injury.
2. All pulleys have speed limitations. Refer to pulley manufacturer's literature for specifications and follow all recommendations, to prevent personal injury.

NAMEPLATE DATA

The Moyno Pump nameplate, located on the bearing housing, carries the serial number, frame size, and type designation. All are extremely important and must be used when ordering spare parts.

Record the nameplate data of your pump in the spaces provided in the heading of Page 3.

Moyno Pumps are identified by Frame and Type. Pump Frame is essentially an indication of size. It consists of a number, a letter, and a number (i.e. 2L10). The first number indicates the number of stages in the pumping elements. The letter indicates the model. The final number indicates the size of the rotor-stator pumping elements. A frame 2L10 pump, therefore, has two stages of size 10 pumping elements.

The “L” in the frame size indicates a standard relationship between the housing, bearings, and drive shaft and the size of the pumping elements. Many variations may be made by adapting smaller element sizes to a larger drive end size. This may be necessary due to the severity of a specific pumping application. In cases where the drive end (housing,

bearings, and drive shaft) is one size larger than the element size normally used, the pump is referred to as an “M” frame pump (i.e. 3M8). If the drive end is two sizes larger than the element size, the pump is referred to as a “P” frame. Thus, a frame 3L10, 3M8 and 3P6 would all use a common drive end.

Type designation is a series of letters which identify the “Materials of Construction” in component groups of parts. The usual type designation will consist of three letters.

The first letter identifies the material of the suction housing casting or the body casting where the bearing housing is a part of the suction housing.

C — Cast Iron
E — Alloy cb-20 Stainless
H — Hastelloy “C”
M — Monel
S — 316 Stainless Steel
W — Cast Steel
X — Special to application

The second letter indicates the material used in the drive shaft, pins, connecting rod, rotor, and other minor metallic parts in contact with the material being pumped.

D — Alloy Steel
E — Alloy cb-20 Stainless
G — 416 Stainless Steel
H — Hastelloy “C”
J — 17-4 PH Stainless Steel
M — Monel
S — 316 Stainless Steel
X — Special to application

The third letter determines the material of the stator. It identifies only the stator material and not that of the tube in which the stator is placed.

B — EPDM 300, 70 Durometer
C — Buna “N” 103, 50 Durometer
D — Tool Steel
E — Buna “N” 110, 70 Durometer
F — Viton 500, 75 Durometer
G — 416 Stainless Steel
H — Hastelloy “C”
J — 17-4 PH Stainless Steel
K — Hypalon 800, 70 Durometer
M — Buna “N” IOOM, 70 Durometer
P — Thiokol 70 Durometer
Q — Buna “N” 100, 700 Durometer
A — Natural Rubber 200, 55 Durometer
T — Teflon 15% glass
U — Urethane 70 Durometer
X — Special to application
Z — Buna “N” 150, 70 Durometer

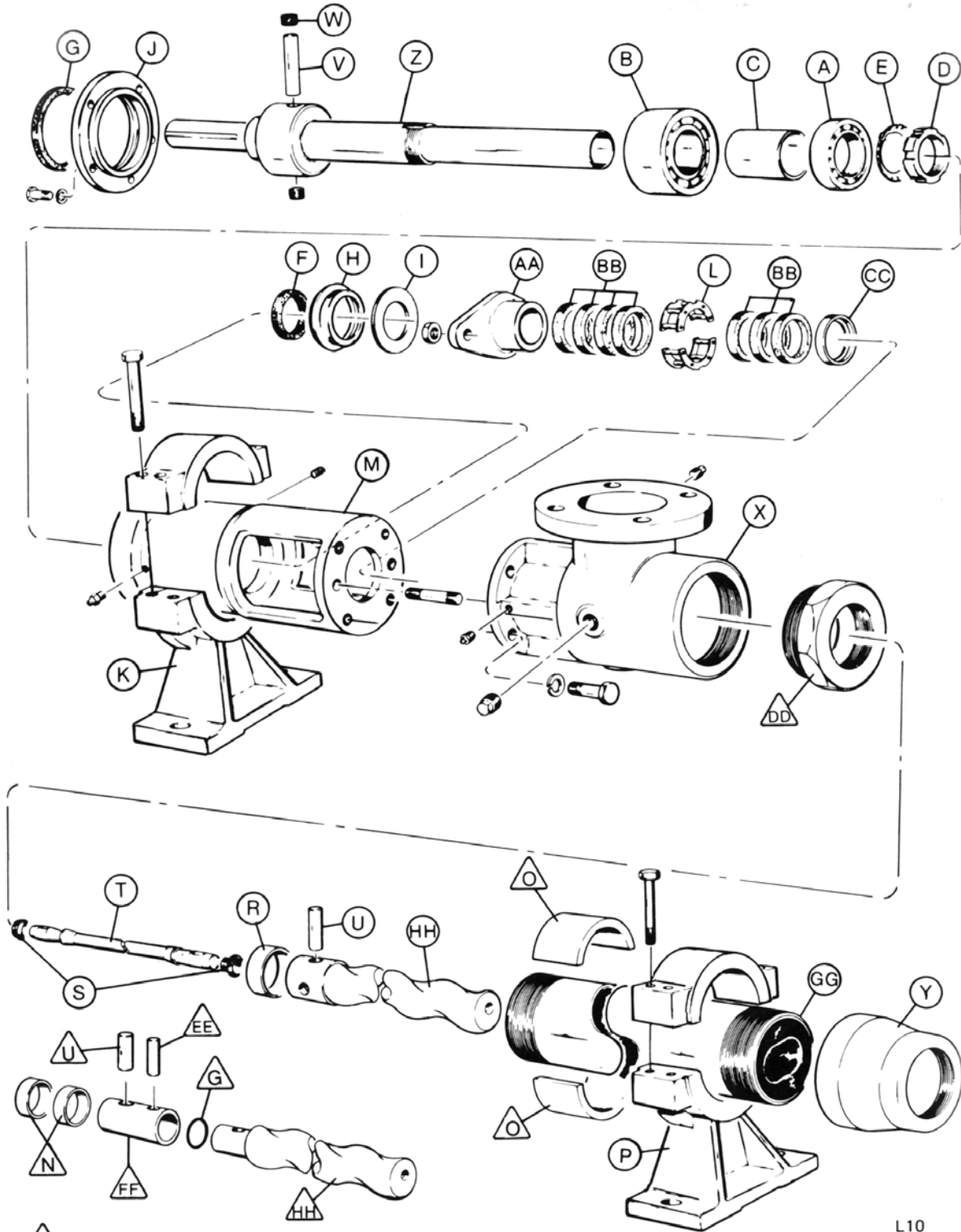

NAMEPLATE DATA

MOYNO PRODUCTS	
PROGRI SSING LEVITY PUMPS	
FRAME NO	_____
TYPE NO	_____
FORM NO	_____
RPM	_____
MEG SERIAL NO	_____
BRANCH SERIAL NO	_____
MFD by Moyno, Inc. Springfield, Ohio U.S.A.	
	

"L10" DRIVE END PARTS TYPE DESIGNATIONS

Select type column corresponding to type designation at left.
Order by part number. Refer to frame size to select proper rotor and stator.

REF.		CDQ	CDD	CSQ	CSD	SSQ	SSD
NO.	DESCRIPTION	CDR	CDG	CSR	CSG	SSR	SSG
		CDB	CDT	CSB	CST	SSB	SST
		CDF		CSF		SSF	
		Part No.	Part No.	Part No.	Part No.	Part No.	Part No.
A.	Ball Bearing (Radial)	A10291	A10291	A10291	A10291	A10291	A10291
B.	Ball Bearing (Thrust)	A10301	A10301	A10301	A10301	A10301	A10301
C.	Bearing Spacer	A10331	A10331	A10331	A10331	A10331	A10331
D.	Bearing Lock Nut	A10581	A10581	A10581	A10581	A10581	A10581
E.	Bearing Lock Washer	A10591	A10591	A10591	A10591	A10591	A10591
F.	Grease Seal (Radial)	A10611	A10611	A10611	A10611	A10611	A10611
G.	Grease Seal (Thrust)	A10621	A10621	A10621	A10621	A10621	A10621
H.	Grease Seal Retainer	A10631	A10631	A10631	A10631	A10631	A10631
I.	Slinger Ring	A10771	A10771	A10771	A10771	A10771	A10771
J.	Bearing Cover Plate	A10341	A10341	A10341	A10341	A10341	A10341
K.	Pump Support	A10371	A10371	A10371	A10371	A10371	A10371
L.	Lantern Ring	A10571	A10571	A10571	A10571	A10571	A10571
M.	Bearing House	A10051	A10051	A10051	A10051	A10051	A10051
N.	Pin Retainer 3M8	A10502	A10502	A10502	A10502	A10502	A10502
O.	Support Bushing 3M8	A10711	A10711	A10711	A10711	A10711	A10711
	3P6, 6P6, 9P6,	A10712	A10712	A10712	A10712	A10712	A10712
P.	Stator Support	A10381	A10381	A10381	A10381	A10381	A10381
	3P6, 9P6	A10382	A10382	A10382	A10382	A10382	A10382
	6P6	A10383	A10383	A10383	A10383	A10383	A10383
Q.	"O" Ring 6P6 Only	A10111	A10111	A10111	A10111	A10111	A10111
R.	Pin Retainer	A10501	A10501	A10501	A10501	A10501	A10501
S.	Connecting Rod Washer	A10531	Not Req'd	A10531	Not Req'd	A10531	Not Req'd
T.	Connecting Rod	B1025D	B1025D	B1025S	B1025S	B1025S	B1025S
U.	Rotor Pin	B1045D	B1045D	B1045S	B1045S	B1045S	B1045S
V.	Shaft Pin	B1046D	B1046D	B1046S	B1046S	B1046S	B1046S
W.	Drive Pin Ret. Screw	B1054D	B1054D	B1054S	B1054S	B1054S	B1054S
X.	Suction Housing	B10021	B10021	B10021	B10021	B10026	B10026
Y.	Reducer - L10, L10H	B10091	B10091	B10091	B10091	B10096	B10096
	3M8	B08091	B08091	B08091	B08091	B08096	B08096
	3P6, 6P6, 9P6	B06091	B06091	B06091	B06091	B06096	B06096
Z.	Drive Shaft +	B10261	B10261	B10266	B10266	B10266	B10266
AA.	Packing Gland	B1041D	B1041D	B1041S	B1041S	B1041S	B1041S
BB.	Packing +	B10421	B10421	B10425	B10425	B10425	B10425
CC.	Packing Washer	B1065D	B1065D	B1065S	B1065S	B1065S	B1065S
DD.	Adapter Bushing 3M8	B10511	B10511	B10511	B10511	B10516	B10516
	6P6, 9P6	B10512	B10512	B10512	B10512	B10517	B10517
EE.	Rotor Head Pin 3M8	B10471	B10471	B10472	B10472	B10472	B10472
	3P6	B10473	B10473	B10474	B10474	B10474	B10474
	6P6	B1045D	B1045D	B1045S	B1045S	B1045S	B1045S
FF.	Rotor Head 3M8	B10321	B10321	B10326	B10326	B10326	B10326
	3P6	B10322	B10322	B10327	B10327	B10327	B10327
	6P6, 9P6	B10323	B10323	B10328	B10328	B10328	B10328
GG.	Stator Frame 1L10	C4110*	C4110*	C4110*	C4110*	C5110*	C5110*
	Frame 2L10	C4210*	C4210*	C4210*	C4210*	C5210*	C5210*
	Frame 3L10	C4310*	C4310*	C4310*	C4310*	C5310*	C5310*
	Frame 1L10H	C4111*	C4111*	C4111*	C4111*	C5111*	C5111*
	Frame 2L10H	C4211*	C4211*	C4211*	C4211*	C5211*	C5211*
	Frame 6P6	C4606*	C4606*	C4606*	C4606*	C5606*	C5606*
	Frame 9P6	C4906*	C4906*	C4906*	C4906*	C5906*	C5906*
	Frame 3M8	C4308*	C4308*	C4308*	C4308*	C5308*	C5308*
HH.	Rotors Frame 1L10 +	C71101	C71101	C81101	C81101	C81101	C81101
	Frame 2L10 +	C72101	C72101	C82101	C82101	C82101	C82101
	Frame 3L10	C73101	C73101	C83101	C83101	C83101	C83101
	Frame 1L10H	C71111	C71111	C81111	C81111	C81111	C81111
	Frame 2L10H	C72111	C72111	C82111	C82111	C82111	C82111
	Frame 6P6	C76061	C76061	C86061	C86061	C86061	C86061
	Frame 9P6	C79061	C79061	C89061	C89061	C89061	C89061
	Frame 3M8	C73081	C73081	C83081	C83081	C83081	C83081

* Add third letter of type designation to complete Part No.
EX: Type CDQ pump Add Q to basic number of stator

+ see pages 5 – 6 for variations

A typical type designation such as COO would result in the following:

- C = Cast Iron Suction Housing
- D = Carbon Steel Internals including drive shaft, pins, connecting rod, rotor, and other minor metallic parts in contact with the material being pumped
- Q = Buna 'N' Synthetic Rubber Stator (70 durometer)

Also included on the nameplate is the three-character trim code designation. This only appears on pumps which have semi-standard or special construction. The first letter identifies sealing variations, the second character identifies internal variations, and the third letter identifies rotor variations.

On page 5 of this manual are variations available for modifying pumps to meet specialized pumping conditions. If the trim code of your pump is other than "AAA", contact your nearest Moyno representative for clarification. Do not use any variation unless you have determined that it is compatible with your application.

INSTRUCTIONS FOR DISASSEMBLY AND ASSEMBLY

Frames 1L10, 2L10, 3L10, 1L10H, 2L10H, 3M8, 3P6, 6P6, 9P6

Disassembly Procedure

1. Disconnect the power source.
2. Close the suction and discharge valves to isolate the pump from the line.
3. Turn off flush water to packing or rotary seal if used.
4. Remove drain plug in suction housing to drain away any fluid remaining in pump.
5. Place a support block under suction housing in area of drain plug. Wooden blocks are sufficient. The purpose is to prevent undue stress on pump support when pump is disassembled.
6. Disconnect piping from stator end of pump.
7. **Stator Removal** - With pipe wrench or strap wrench remove discharge reducer (Y). Remove cap of stator support and with strap wrench or pipe wrench, unscrew the stator (GG) from the suction housing. Pull Stator off the rotor.
8. **Rotor Removal** - The rotor (HH) is removed with the connecting rod (T) and rotor pin (U) as a unit. Removal of the unit is accomplished by removing the two drive pin retaining screws (W). This step reveals the shaft drive pin (V) which is removed by driving the pin from the drive shaft (Z) with a small punch or drift pin. The rotor and connecting rod can now be removed by pulling them from the pump. To disassemble, clamp the connecting rod (T) by its mid-section in a vise and with a drift pin, drive the pin retainer (R) from the head of the rotor. The rotor pin (U) can now be removed from the rotor freeing the connecting rod. Remove the connecting rod washers (S) if present. On most "M" and "P" frame pumps a detachable rotor head (FF) is present. On these pumps two pin retainers (N) are present to retain the rotor head pin (EE). An "O" ring (Q) is present only on frame 6P6 pumps.
9. To remove packing (BB), remove nuts holding packing gland (AA). Slip packing gland from

studs, remove packing rings, lantern ring (L), and remaining packing rings. Packing rings can be removed with a standard packing puller. Note: If step 10 is to be performed, it should precede step 9 as packing can then be removed by freeing packing gland and driving packing, lantern ring, and packing washer (CC) from housing using a small rod. Rod should enter where stator screws into suction housing. Place rod on packing washer and tap. Entire set should easily exit from opposite end of stuffing box.

10. **Drive Shaft & Bearing Removal** - With rotor removed it is now possible to remove the drive shaft and bearings as a sub-assembly. Remove the four cap screws holding the bearing cover plate (J) and slip from shaft. Insert a bar or rod into the hollow end of drive shaft (Z) where it enters the suction cavity. By tapping on the rod the entire assembly will be forced from the bearing housing.

Assembly Procedure

Moyno pumps are reassembled in the reverse order of disassembly with special notes as outlined below:

1. Always replace all old washers, "O" rings, and packing. We also recommend replacing grease seals when new bearings are installed.
2. **Bearing Shaft Assembly** - When installing new bearings, make sure that they are seated against the shoulder on the shaft. Replace bearing lock washer and bearing lock nut. Tighten bearing lock nut securely. Bend tab down onto lock nut to prevent loosening of nut. Make sure that the packing gland and packing washer are installed on the drive shaft as the hollow end emerges in the bearing housing and approaches the stuffing box area. When replacing the bearing cover plate tighten all cap screws evenly to prevent damage to the bearing cover plate and thrust grease seal.
3. **Do not over-lubricate bearings. (See Maintenance)** When installing the connecting rod, make sure that the hole in the rod is aligned with the holes in the drive shaft **before** inserting the pin. Make sure that the hollowed end of the retaining screw fits over the end of the shaft pin to ensure a tight fit.
4. When replacing packing, insert three rings on the shaft, the lantern ring, and then four more rings. This will allow the lantern ring to line up with the grease fitting on the stuffing box. **Make sure you stagger the ends of the packing rings.** When installing the new packing, you may find that all but one ring will go on the drive shaft. When the pump has run for a short time and the new packing is compressed, this final ring can be installed.
5. When installing the stator on the rotor, it is best to lubricate the rotor with water (or a lubricant compatible with the rubber in the stator) to allow the stator to slip on easier. (Grease or oil is not compatible with type "A" or "B" stators.) When replacing the stator, always tighten it with the pipe wrench on the end of the stator nearest the suction housing. This will prevent it from binding and damaging the threads. If your stator has a stainless steel sleeve, use a teflon tape or similar material on the threads before replacing -- on all stators with a carbon steel sleeve, use pipe dope.

6. Caution: Dry operation is harmful to the pump. Always fill the pump with fluid to be handled prior to start up. Check any valves in discharge line to determine that no restrictions exist.

MAINTENANCE

The Moyno pump has been designed for a minimum of maintenance, the extent of which is routine lubrication and adjustment of packing and infrequent lubrication of the bearings. The pump is one of the easiest to work on in that the main elements are very accessible and require few tools to disassemble.

Packing

The Moyno pump is normally furnished with die formed packing. The packing may be either grease lubricated through a grease fitting in the stuffing box or have plumbing connected to the housing to allow a water flush. (See Water Flush of Packing) Packing gland adjusting nuts should be evenly adjusted so they are little more than finger tight. Over-tightening of the packing gland may result in premature packing failure and possible damage to the shaft and gland. When the packing is new, frequent minor adjustments are recommended for the first few hours of operation in order to compress and seat the packing. Greasing the packing often but with limited quantities of grease is the best practice. This can be done through a grease fitting which leads to a lantern ring in the mid-section of the packing. Do not use a

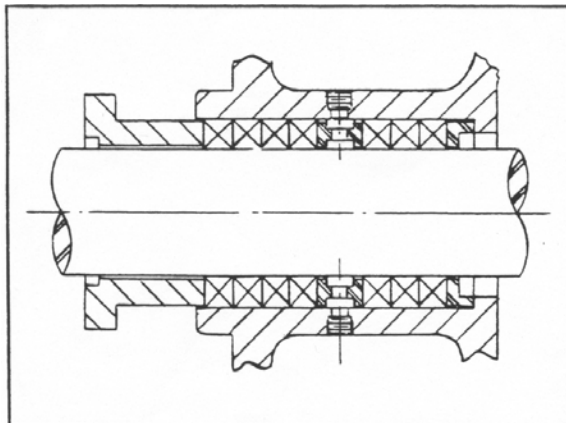

Cross section of stuffing box

one-piece spiral wrap of packing.

Water Flush of Packing

When the material being pumped is abrasive in nature, it may be advantageous to flush the packing to prevent leakage under packing and excessive shaft wear.

Clean water can be injected through a 1/8" NPT tapped hole that normally houses the grease fitting for lubricating the packing. The water can be permitted to leak axially along the shaft in either direction or can be removed from the second tapped hole in the stuffing box. In both cases, the discharge from the stuffing box should be throttled slightly to maintain 10-15 PSI higher pressure in the stuffing box than is present in the suction housing.

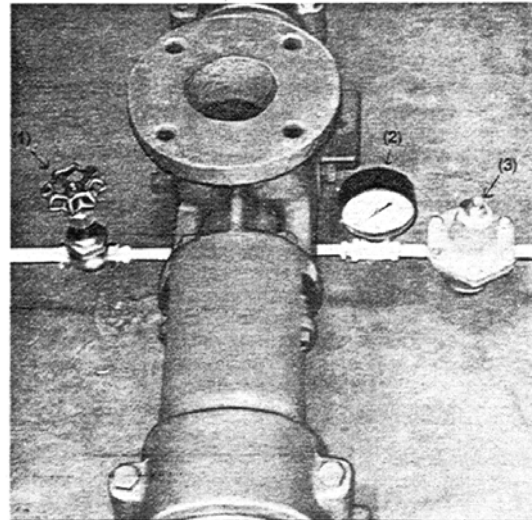

Typical water Flush to packing

This is a basic arrangement, other variations can be used. (1) Throttling Valve (2) Pressure Gauge (3) Pressure Regulating Valve

Bearings

The Moyno pump is equipped with ball bearings in the drive end size L2 through L10. The bearings are lubricated at the factory and do not need additional lubrication for at least 1500 hours of normal operation.

When relubricating the bearings, the bearing-shaft assembly should be removed (See Disassembly instructions) and cleaned of old grease. Add only enough grease to fill the area between the bearings 1/3 full. Add a few drops of oil to bearing seals before reassembling. It is normal for bearings to run warm to the touch for the first few hours of operation.

Any type of Ep Lithium soap base grease is satisfactory for bearing lubrication. The use of Sodium or Calcium base grease is not recommended.

The following is a partial listing of approved bearing lubricants:

Dow Corning	DC33
Keystone Lubricating Co.	Keystone #89
Texaco	Regal AFB2
Shell Oil Co.	Cyprina #3
Humble Oil & Refining Co.	Beacon 325
American Oil Co.	Supermil Grease #A72832
Mobil	EP1
Shell Oil Co.	Alvania #2

VARIATIONS OF STANDARD PARTS

Below are variations available for modifying pumps to meet specialized pumping conditions. If the trim code of your pump is other than "AAA," contact your nearest Moyno representative for clarification. Do not modify your pump with any variation unless you have determined that it is compatible with your application.

The three-character trim code is designed as follows. The first character identifies any sealing variations, the second character identifies any internal variations, and the third character identifies any rotor variations.

The trim code "AAA" represents a pump with standard features. Deviations from standard are to be indicated by changing the appropriate character from the choices listed. When two or more letters are combined, dashes are used to separate the three areas of the trim code for clarity.

SEALING VARIATIONS

- A — BRAIDED TEFLON & GRAPHITE PACKING, (Black) Standard to all lines except Quick Disassembly pumps. Optional on Quick Disassembly pumps.
- C — BRAIDED TEFLON PACKING, (White) Optional packing on all lines.
- D — DOUBLE MECHANICAL SEAL, Optional on all lines. Not offered on #2 "L" frame.
- F — BRAIDED TEFLON FOOD GRADE PACKING, (White) Standard on all Quick Disassembly pumps. Optional on all other lines.
- G — 100% GRAPHITE PACKING, (Gray) Optional to all lines.
- S — SINGLE MECHANICAL SEAL, Optional on all lines.
- W — WATER FLUSH, Optional on all lines.
- X — Special to application.

INTERNAL VARIATIONS

- A — Standard plated shaft
- B — Non-plated shaft
- C — Solid drive shaft configuration
- D — Grit seal, for "L" frame only
- E — Extension tube with extended auger
- F — Extended drive shaft (for back stop or large pulley)
- G — Ceramic coating
- S — Shaft sleeve
- X — Special to application

ROTOR VARIATIONS

- A — Standard size with chrome plating
- B — Non-plated (no plating)
- C — Standard undersize
- E — Standard oversize
- F — Counter clockwise rotation (Centennial line only)
- G — Ceramic coating
- X — Special to application

ROTORS identified on parts listing are standard size with hard-chrome plated surface. Other variations of rotor size and finish may be ordered by selecting the standard rotor part number and changing the last digit of the rotor number as follows:

- 2 = Standard size, non-plated
- 3 = Undersize, chrome-plated
- 4 = Undersize, non-plated
- 5 = Oversize, chrome-plated

Do not change rotor sizes without consulting your local Moyno Sales Office. These variations are used for certain specialized pumping conditions only.

PACKING VARIATIONS listed are common to most type designations. Others may be specified by changing the last digit to the following:

- 1 = Standard on all type CDQ pumps
- 3 = Standard on all type CDR & SSR pumps
- 5 = Standard on all type SSQ pumps
- 7 = Optional--Solid Braided Teflon
- 8 = Optional--Teflon impregnated white asbestos

DRIVE SHAFTS shown have hard-chrome plating on the packing wear area. If non-plated drive shafts are required, select the standard part number and change the last digit to next higher number. Example: B10261 to B10262.

L10 STANDARD HARDWARE

ITEM	SIZE	# REQ.
Bearing Cover Plate Screw	1L x 1/2D-13	5
Lock Washer		5
Suction Housing Bolt	2L X 3/4D-10	4
Lock Washer		4
Stator & Pump Support Screw	4L X 1/2D-13	4
Packing Gland Stud	4L X 1/2D-13	2
Drain Plug on Stuffing Box	1/8D	2
Suction Housing Drain Plug	1/2D	3
Bearing Housing Drain Plug	1/8D	2
Hex Key	9/16	1

RECOMMENDED SPARE PARTS

The Moyno pump has been designed and built with all wearable parts replaceable. A recommended inventory of spare parts is dependent upon the application and importance of continued operation.

For the shortest possible down time, we recommend the following parts be stocked:

- 1 - Rotor
- 1 - Stator
- 1 - Connecting Rod
- 2 - Connecting Rod Washers
- 1 - Rotor Pin
- 1 - Shaft Pin

The above is only a suggested list. For further assistance in determining what you'll need for your application, contact your Moyno representative.