



P&PE

PUMPS & PROCESS EQUIPMENT INC.

To Request a Quote,

CALL US 1-847-882-8116

SERVICE MANUAL

MOYNO[®] 1000 Pumps



MOYNO

Always the Right Solution™

TABLE OF CONTENTS

	Page		Page
1-1. INTRODUCTION	1		
1-2. GENERAL.....	1	4-21a. Mechanical Seals.....	7
1-3. SCOPE.....	1	4-22. Packing.....	7
1-4. NAMEPLATE DATA.....	1	4-23. Rotor.....	7
1-5. Pump Rotation.....	1	4-24. Stator.....	7
1-6. Model Number.....	1	4-25. All Other Parts.....	7
2-1. INSTALLATION	2	4-26. ASSEMBLY.....	7
2-2. GENERAL.....	2	4-26a. One-Piece Shaft-	
2-3. PIPING.....	2	Ball Bearing Models.....	7
2-4. Suction Piping.....	2	4-26b. One-Piece Shaft-	
2-5. Discharge Piping.....	2	Tapered Roller Bearing Models.....	7
2-6. FOUNDATION.....	2	4-27. Two-Piece Shaft Models.....	8
2-7. SHAFT ALIGNMENT.....	2	4-27a. Ball Bearing Models.....	8
2-8. Coupling Connected Units.....	3	4-27b. Tapered Roller Bearing Models.....	8
2-9. Belt Drive Units.....	3	4-28. Close-Coupled Models.....	8
3-1. OPERATION	3	4-29. Adjusting Bearing End Play	8
3-2. INITIAL CHECK.....	3	4-30. Shaft Installation.....	8
3-3. START-UP.....	3	4-30a. Single Mechanical Seal...	9
3-4. PACKING LEAKAGE.....	3	4-30b. Double Mechanical Seal.....	9
4-1. MAINTENANCE	3	4-31. Connecting Rod or Auger	
4-2. GENERAL.....	3	Assembly.....	9
4-3. PACKING ADJUSTMENT.....	3	4-32. Suction Chamber.....	10
4-4. PACKING REPLACEMENT.....	4	4-33. Stator.....	10
4-5. BEARING LUBRICATION.....	4	4-34. Stator/Support/Discharge	
4-6. DRIVE SHAFT AND ROTOR-		Flange Assembly.....	10
EXTENDED LIFE PROVISION.....	4	4-35. Packing.....	10
4-7. DISASSEMBLY.....	4	4-36. Pump Connections.....	10
4-8. Disconnect Pump.....	4	4-37. STORAGE.....	10
4-9. Stator Removal.....	4	4-37a. Short-Term Storage.....	10
4-10. Suction Chamber Removal.....	5	4-37b. Long-Term Storage.....	11
4-11. Rotor Removal.....	5	4-38. STANDARD PACKING	
4-12. Connecting Rod or Auger		SPECIFICATION.....	11
Assembly Removal	5	4-39. RECOMMENDED SPARE PARTS.....	11
4-13. Packing Removal.....	5	4-40. HOW TO ORDER SPARE PARTS.....	11
4-14. Drive Shaft Removal.....	5	4-41. STANDARD HARDWARE LIST-	
4-15. Bearing Removal.....	6	STANDARD AND OPEN THROAT	
4-16. Gearbox/Gearmotor Removal.....	6	MODELS.....	12
4-17. CLEANING.....	6	4-42. STANDARD HARDWARE LIST-	
4-18. INSPECTION.....	6	CLOSE-COUPLED MODELS.....	13
4-19. Bearings.....	6	4-43. EXPLODED VIEWS.....	13
4-20. Drive Shaft and Intermediate		4-44. Standard Model-Ball Bearing	
Shaft.....	6	Design Drive End.....	13
4-21. Seals.....	6	4-45. Standard Model-Roller Bearing	
		Design Drive End.....	14
		4-46. Close-Coupled Models.....	15
		4-47. Open Throat Models.....	16
		4-48. PARTS LIST.....	18
		4-49. TROUBLESHOOTING CHART.....	28

SERVICE MANUAL

MOYNO® 1000 PUMPS

1-1. INTRODUCTION

1-2. GENERAL

The Moyno 1000 pump is the most versatile positive displacement pump available. Its design parameters have been proven in thousands of applications over the past 60 years, and it is backed by this same half century-plus of experience in application and manufacturing know-how.

The Moyno 1000 pump is a progressing cavity pump. The pumping action is created by a single helical rotor rolling eccentrically in the double-threaded helix of the stator. In its revolution, the rotor forms, in conjunction with the stator, a series of sealed cavities 180 degrees apart. As the rotor turns, the cavities progress from the suction to the discharge. As one cavity diminishes, the opposing cavity increases at exactly the same rate. Thus, the sum of the two discharges is a constant volume. The result is a pulsationless, positive displacement flow.

1-3. SCOPE

This service manual covers the standard, close-coupled, and open throat configurations of the Moyno 1000 pump line. Disassembly and assembly procedures are also covered in this manual.

1-4. NAMEPLATE DATA

The pump nameplate, located on the bearing housing, or drive adaptor, contains important information relative to the operation and servicing of the pump. This information includes the direction of rotation arrow and the pump model and serial numbers.

The model and serial numbers must be used when ordering spare parts. To facilitate parts ordering, the nameplate data for your pump has been recorded on the nameplate drawing on the front cover of this manual.

1-5. Pump Rotation. The direction of rotation is indicated by a rotation arrow on the nameplate. Standard rotation of Moyno 1000 pumps is clockwise, when viewed from the driven end of the pump. Close-coupled models only, are not to be run in reverse.

1-6. Model Number. The pump model number is a series of letters and numbers which identifies the pump's basic design and materials of construction. A typical model number, for example, might be A2E CDQ3AAA, as shown on the nameplate in Figure 1-1.

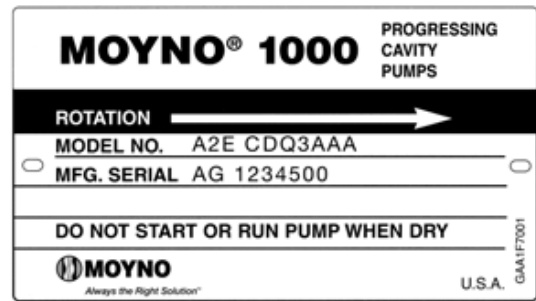

Figure 1-1. Typical nameplate showing rotation arrow, model, and manufacturing serial numbers.

The first three letters and numbers identify the pump's basic design characteristics.

In the first space, a letter designates the pump type. Letters used and their corresponding design types are as follows:

A = Standard	D = High Abrasion, Standard
B = Close-coupled	E = High Abrasion, Close-coupled
C = Open throat	

The second position number identifies the number of stages in the pumping elements. This will generally be a 1, 2, or 4.

The third position is a letter, A through K, which identifies the pump's capacity in terms of gallons (gal.) per 100 revolutions. Sometimes the third position is followed by the letter "E" which denotes the pumping element is our Ultra Pro 23 geometry. The letters, with their corresponding capacities, are:

A – .38 gal./100 revs.	G – 22.0 gal./100 revs.
B – .75 gal./100 revs.	H – 36.0 gal./100 revs.
C – 1.5 gal./100 revs.	J – 48.0 gal./100 revs.
D – 3.0 gal./100 revs.	K – 62.0 gal./100 revs.
E – 6.0 gal./100 revs.	L – 115.0 gal./100 revs.
F – 12.0 gal./100 revs.	

The next 3 positions, always letters, describe the pump's "Materials of Construction" in component groups of parts.

The first letter in this group identifies the material of the suction chamber casting.

The second letter indicates the material used in the rotating parts, i.e., the drive shaft, connecting rod, rotor,

and other metallic parts in contact with the material being pumped.

The third letter indicates the material of the stator. It identifies only the stator material and not that of the tube in which the stator is placed. The tube, a non-wetted part, is always alloy steel.

A typical designation such as the CDQ used in our example would result in the following:

- C = Cast iron suction chamber
- D = Hardened alloy steel internals including drive shaft, connecting rod, pins, and rotor
- Q = Nitrile (NBR) stator (70 durometer hardness)

The following letters identify the materials used in standard construction:

- C = Cast iron
- D = Hardened alloy steel
- S = Stainless steel, Type 316
- Q = Nitrile (NBR), 70 durometer hardness
- B = EPDM
- F = Fluoroelastomer

The next position is a number identifying the current pump revision, this manual corresponds to revision 3.

The last three letters indicate the trim code and denote internal variations in a pump. The first letter identifies sealing variations. The second letter indicates internal variations. The third letter indicates rotor variations.

A typical trim code is AAA, designating the following:

- A = Standard black packing
- A = Standard plated shaft
- A = Standard size chrome-plated rotor

The variations available are:

Sealing:

- A – Standard black packing
- C – Teflon⁷ white packing (not food grade)
- S – single mechanical seal
- D – Double mechanical seal

Internal variations:

- A – Standard plated shaft
- B – Non-plated shaft
- P – Two-piece shaft or pinned close coupled

Rotor variations:

- A – Standard plated rotor
- B – Non-plated rotor
- C – Standard undersize
- E – Standard oversize
- X – Special to order

2-1. INSTALLATION

2-2. GENERAL

Accessibility to the pump and adequate clearance should be prime considerations in any installation. Enough space should surround the unit so that maintenance can be performed with ease.

2-3. PIPING

2-4. Suction piping should be as short as possible. Normally, the suction line should be the same diameter as the pump suction; however, conditions such as high viscosity or required minimum flow velocities may dictate otherwise. Long-sweep 90 degree elbows or 45 degree elbows should be used instead of the standard elbow. Avoid using suction piping loops which trap air.

2-5. Discharge piping diameter should generally be as large as the discharge port unless fluid conditions indicate otherwise.

An easily-removable section of piping, at least twice as long as the stator, should be mated to the discharge port. This will allow the rotor and stator to be removed without having to remove the complete pump from the base.

2-6. FOUNDATION

For maximum pump-driver unit life, each unit should be mounted on a strong steel baseplate. The baseplate should be mounted on a firm foundation. The motors should be supported on close-coupled configurations above 1 HP.

2-7. SHAFT ALIGNMENT

After the base has been bolted down to the foundation, check the following conditions:

2-8. Coupling connected units. Be sure that the pump and drive shafts are aligned before the coupling is connected. Care should be exercised to ensure that all components are level and mounted in a direct line.

Check the gap between coupling halves (refer to coupling manufacture's recommendations). Adjustment can usually be made by loosening the mounting bolts on either the pump or driver and moving the loosened component into alignment with the fixed component. Do not use a hammer! On couplings with equal diameter hubs, it may be helpful to lay a straight edge across the coupling halves to check alignment.

2-9. Belt drive units. Be sure that sheaves or sprockets are in alignment. Check belts for proper tension. Tension requirements will vary with type of belt, center distances, and belt speeds. Consult belt manufacturer for specific recommendations.

3-1. OPERATION

3-2. INITIAL CHECK

Before putting the pump into operation, the following items should be checked to ensure that each piece of equipment is installed correctly:

- Pump, driver, coupling, or sheave alignment.
- Electrical connections.
- Gauges and other instruments.
- Pump rotation. Rotation is indicated on the pump nameplate.
- Belt tension on belt driven units. There should be no appreciable deflection when first starting up.
- All valves should be open on both suction and discharge sides of pump.
- Seal flush systems if required should be operational. Double seals require flushing between faces.

CAUTION: This is a positive displacement pump. Do not operate it against a closed valve.

3-3. START-UP

CAUTION: DRY OPERATION IS HARMFUL TO THE PUMP! Never allow the pump to operate without liquid, as dry operation will cause premature wear of the stator and possible damage. The stator is lubricated by the liquid which is being pumped.

1. Before operating the pump for the first time, fill it with liquid to lubricate the stator for the initial start-up.

Note: If the pump is shut down temporarily, enough liquid will remain in the system to provide lubrication upon restarting. It is advisable to maintain the suction piping at a higher elevation than the centerline of the pump in order to contain some liquid in the pump at time of shutdown.

2. Once the pump has been filled with liquid, check for direction of pump rotation by momentarily starting and stopping the drive. See pump nameplate for correct rotation.
3. Start seal flush water if so equipped.
4. Start pump.

3-4. PACKING LEAKAGE

The packed stuffing box is designed to control leakage, not stop it completely. Leakage is necessary to reduce friction and dissipate heat.

In a new pump, before the packing has had a chance to seat properly, excessive leakage through the stuffing box is common. Frequent adjustments of the packing gland may be necessary during the first few hours of operation in order to compress and seat the packing. See Section 4-3.

4-1. MAINTENANCE

4-2. GENERAL

The Moyno 1000 pump has been designed for a minimum of maintenance, the extent of which is routine adjustment of the packing, and infrequent lubrication of the bearings in tapered roller bearing models. The pump is one of the easiest to work on because the main elements are very accessible and require few tools to disassemble.

4-3. PACKING ADJUSTMENT

Packing gland nuts (see Figure 4-1) should be evenly adjusted. Overtightening the packing gland may result in premature packing failure and possible damage to the shaft and gland.

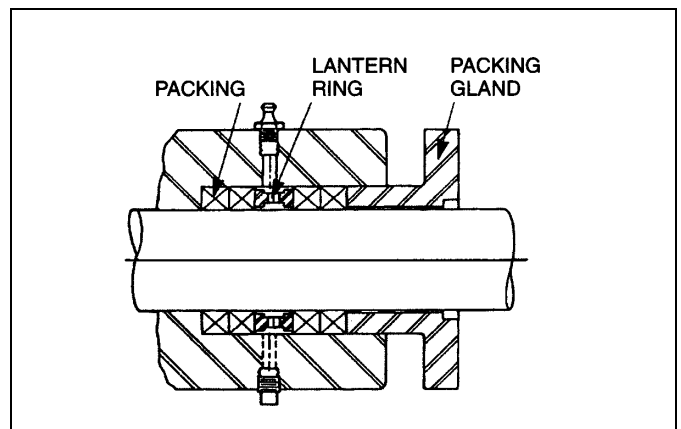

Figure 4-1. Cross Section of Packing Retainer

When packing is new, frequent minor adjustments during the first few hours of operation are recommended in order to compress and seat the packing.

1. Upon initial start-up of the pump, adjust the gland nuts for a leakage rate of 50-100 drops per minute until the packing has seated and adjusted to the operating temperature (approximately 10-15 minutes).
2. If leakage is excessive after 15 minutes of operation, tighten the gland nuts $\frac{1}{4}$ of a turn.
3. Tighten the gland nuts $\frac{1}{4}$ of a turn after an additional 15 minutes if necessary and repeat this procedure until a desired leakage of 1-2 drops per minute is obtained. Adding grease may also reduce leakage by providing a barrier at the lantern ring.

CAUTION: Do not tighten until zero leakage is obtained. Overtightening the packing gland may result in accelerated wear on the packing and damage to the shaft. In those situations where no packing leakage can be tolerated, consult your Moyno Authorized Service Distributor.

4-4. PACKING REPLACEMENT

Note: In this section, the first reference to each pump part will be followed by a number or a letter in parentheses (). These numbers and letters are those used to identify the pump parts and hardware items in the Exploded Views in Section 4-43.

When leakage can no longer be regulated by tightening the gland nuts, remove and replace the packing. The entire pump need not be disassembled to replace the packing. Briefly, replace as follows:

1. Remove packing gland nuts and lock washers and slide gland (0900) and slinger ring (6800) back along drive shaft (6000).
2. Use a packing puller tool (see Figure 4-2) to remove the packing (6900).



Figure 4-2. Packing Removal Tool

3. Inspect surface of drive shaft for excessive wear or grooves due to packing rub. If shaft is worn, or is badly scored or grooved, it should be replaced.
4. If drive shaft is not worn, install a lantern ring and 4 packing rings, lubricating them before installation with a good grade of packing grease. Be sure to stagger the packing ring joints at 90 degrees increments.

Note: The stuffing box is supplied with 4 rings installed, a fifth ring may be added after initial compression.

CAUTION: ALWAYS USE A PROPER PACKING TAMPER TOOL TO INSTALL PACKING. Do not use a pointed or sharp tool, as damage to the packing material or drive shaft could result. To assure proper shaft lubrication, never use a one-piece spiral wrap packing.

5. Replace packing gland and secure with packing gland screws (H), lock washers, and nuts.
6. Adjust packing per Section 4-3.

4-5. BEARING LUBRICATION (BEARING MODELS ONLY)

There are two types of bearings used in Moyno 1000 pumps. The smaller models utilize ball bearings which are lubricated and permanently sealed by the bearing manufacturer. These bearings cannot be lubricated in service and generally, due to their low cost and availability, are changed periodically during routine maintenance operations.

The larger pumps, including all open throat models, utilize tapered roller bearings which can be relubricated. Under normal operating conditions, bearings should not require replacement or relubrication for at least 15,000 hours or every 2 years.

To lubricate tapered roller bearings:

1. Remove the drive shaft assembly and the bearings in accordance with DESASSEMBLY instructions, Sections 4-14 and 4-15.
2. Clean bearing cups and cones and the shaft assembly to remove all old grease.
3. Use a good grade of EP (Extreme Pressure) Lithium soap-base grease such as Mobilux EP2 (Mobil Chemical Co.), Shell Alvania EP2 (Shell Oil Co.), or equivalent, to lubricate bearings.
4. Reassemble in accordance with the ASSEMBLY instructions, Section 4-26.

4-6. DRIVE SHAFT AND ROTOR-EXTENDED LIFE PROVISION

The heads on the drive shaft and rotor of Moyno 1000 pumps are manufactured with two sets of drive pin holes located 90 degrees apart.

If, after many hours of service, pin hole wear is encountered, the drive shaft and/or rotor may be rotated 90 degrees and the second set of pin holes utilized.

4-7. DISASSEMBLY

Note: In this section and in following sections on CLEANING, INSPECTION, and ASSEMBLY, the first reference to each pump part will be followed by a number or letter in parentheses (). These numbers and letters are those used to identify the pump parts and hardware items in the Exploded Views in Section 4-43.

4-8. Disconnect Pump

1. Disconnect the power source.
2. Close suction and discharge valves to isolate the pump from the line.
3. Remove drain plug (N or P) in bottom of suction chamber (1100) to drain any fluid remaining in pump and suction line.

4-9. Stator Removal

1. Remove section of discharge pipe attached to discharge flange (1400).
2. Remove discharge flange (1400) by unbolting from stator clamp ring (1800) and remove stator gasket (1200). Remove stator retaining ring (R) and stator clamp ring (1800) from stator (6500).

3. Remove top half of stator support (1700).

4. Unbolt stator clamp ring (1800) from suction housing, remove stator from rotor, turning stator while removing will ease disassembly. Use a screwdriver tip to carefully remove the stator retaining ring. Remove stator clamp ring (1800) from stator (6500). See Figure 4-3 for the typical retaining ring removal procedure.

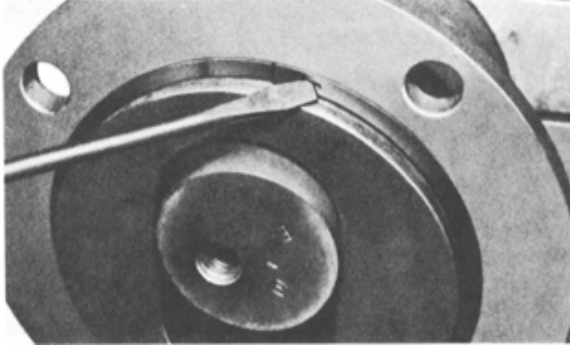

Figure 4-3. Typical Retaining Ring Removal

Note: On some four-stage models, a stator adaptor (1500) and gasket (1210) will be installed between the stator and suction chamber.

4-10. Suction Chamber Removal

1. On standard and close-coupled models, remove four suction chamber bolts and lock washers (M) holding suction chamber to bearing housing (0100). On open throat models, studs (O) screwed into the bearing housing are used in place of the suction chamber bolts. Remove four suction chamber nuts and lock washers (O) holding suction chamber to bearing housing. Remove stator gasket from housing.

2. Remove suction chamber and suction chamber gasket (1220) over the connecting rod (6200) and rotor on standard models or auger assembly (6200) and rotor on open throat models.

4-11. Rotor Removal

1. With snap ring pliers, remove the rotor head snap ring (J), sliding it down over the rotor. Some models may use spiral type rings (see Figure 4-3).

2. Carefully tap the retaining ring (6100) towards the rotor end exposing the edge of the universal joint seal (6400).

3. Remove the edge of the universal joint seal from the groove in the rotor head and fold the seal back.

4. Carefully tap the retaining ring back towards the universal joint seal until the drive pin (6300) is exposed.

5. Push the drive pin through the rotor head and remove the rotor.

6. Remove head O-ring (K) from rotor head.

4-12. Connecting Rod or Auger Assembly Removal

1. Remove the drive shaft head snap ring (J) sliding it back towards the bearing housing. Some models may have spiral type rings (see Figure 4-3).

2. Tap the retaining ring towards the bearing housing, exposing the edge of the universal joint seal.

3. Remove the edge of the universal joint seal from the groove and fold the seal back.

4. Slide the retaining ring back towards the seal until the drive pin is exposed.

5. Push the drive pin through the drive shaft head and remove the connecting rod or auger assembly from the drive shaft (6000).

6. Remove head O-ring from drive shaft head.

4-13. Packing Removal

To remove packing without removing the drive shaft and bearing assembly, refer to Section 4-4. If the drive shaft and bearing assembly are to be removed, proceed directly to Sections 4-14 and 4-15.

4-14. Drive Shaft Removal

Shaft Drive Models (one-piece shaft, not close-coupled)

The Moyno 1000 pump is designed so that the stuffing box (1000), packing gland, packing, and bearings (D or E) are removed as an assembly with the drive shaft. **For Close-Coupled models, skip to Step 17. For two-piece Shaft Drive models, skip to Step 6.**

1. Remove the drive shaft key (I).

2. Remove bearing cover screws and lock washers (A).

Note: Ball bearing models do not have a bearing cover. A bearing housing snap ring (G), located at the drive shaft end of the bearing housing, is used to position the drive shaft and bearings. This snap ring need not be removed.

3. Slide bearing cover (0300) with grease seal (B) and bearing shims (6700) off of drive shaft.

4. Using snap ring pliers, remove the bearing housing snap ring (G) located at the stuffing box end of the bearing housing.

5. Slide drive shaft assembly from bearing housing.

Shaft Drive Models (two-piece shaft, not close-coupled)

The Moyno 1000 pump is designed with a two-piece drive shaft available that allows for removal of the drive shaft head for easy seal maintenance.

6. Remove drive shaft key (I).

7. Move slinger/pin retainer (6800) toward packing or seal housing, exposing shaft pin.

8. Remove shaft pin (2000).
 9. Pull intermediate shaft from bearing housing assembly (2100).
 10. Inspect the sealing O-ring (2200) and replace if worn or damaged.
 11. Remove mechanical seal and seal housing from bearing housing, or remove packing stuffing box from bearing housing.
 12. Remove bearing cover screws and lock washers.
- Note: Ball bearing models do not have a bearing cover. A bearing housing snap ring, located at the drive shaft end of the bearing housing, is used to position the drive shaft and bearings. Remove this snap ring.
13. Slide bearing cover (0300) with grease seal (B) and bearing shims (6700) off of drive shaft.
 14. Slide the drive shaft/bearing assembly out of the bearing housing toward the bearing cover end.
 15. Remove, if desired, the bearing housing snap ring (G) located at the stuffing box end of the bearing housing.
 16. This allows removal of the grease seal housing. Inspect and replace grease seal if worn or damaged.

Close-Coupled Models Only

The Moyno 1000 close-coupled pump is designed so that the stuffing box, packing gland, and packing are removed as an assembly with the drive shaft.

17. Pull back slinger ring on pinned versions, and push out the pin.
18. On keyed versions, remove set screws (D) in locking ring (1600). Rotate locking ring 90 degrees. Slide drive shaft assembly from drive adaptor, uncoupling from output shaft of drive.

Note: There is a flange on the gearbox side of the locking ring that catches on the back end of the drive shaft key. By rotating 90 degrees the set screw holes should be 90 degrees from the key. This will align a clearance in this locking ring for removal.

4-15. Bearing Removal (Not Close-Coupled)

1. Remove shaft snap rings (F).
2. Use an arbor press to press bearings from drive shaft. The first bearing is pressed off with its accompanying grease retainer (0500). Slide the second grease retainer off the shaft and then remove the second bearing.

Note: When replacing drive shaft or bearings on tapered roller bearing models, it is recommended that both grease seals be replaced.

3. Remove the grease seal housing (0700) and grease seal, bearing housing snap ring, slinger ring, packing gland, packing, and stuffing box from drive shaft, on one-piece shaft models.

4-16. Gearbox/Gearmotor Removal Close-Coupled Models Only - Pinned and keyed

1. To remove the gearbox/gearmotor from the pump, remove the bolts holding the gearmotor to the drive adaptor.
2. Pull back slinger ring on pinned versions, and push out the pin.
3. On keyed versions, loosen and remove two set screws in the locking ring. **Rotate locking ring 90 degrees in either direction.**
4. Disengage gearmotor shaft from the pump drive shaft.

Note: Rotating locking ring aligns the slots in locking ring with shaft key to allow disengagement.

4-17. CLEANING

Clean parts in a suitable cleaning solvent.

4-18. INSPECTION

4-19. Bearings. As described in Section 4-5 on Bearing Lubrication, ball bearings (E) are sealed by the manufacturer and are not designed to be relubricated and reused. The following inspection procedure applies to tapered roller bearings (D).

1. After cleaning, rotate bearings very slowly under hand pressure to feel for smooth and even action. Never spin a dry bearing. Check for cracks, galling, pitting, burns, etc. Replace bearing if there is any doubt concerning complete serviceability; bearings should be readily available from any bearing source.

4-20. Drive Shaft and Intermediate Shaft. Inspect drive shaft (6000) and intermediate shaft (2100) if so equipped for scoring, burrs, cracks, etc. Replace as necessary. The drive shaft head is equipped with two sets of pin holes. When one set becomes worn, rotate shaft 90 degrees and use second set.

4-21. Seals. It is sound practice to always replace grease seals (B) whenever the drive shaft and tapered roller bearings are removed.

4-21a. Mechanical Seals. It is sound practice to replace mechanical seals when the pump is disassembled. Extreme care should be taken to protect the seal faces from damage. These are fragile; avoid touching the faces and keep them clean.

The rubber bellows (Type 43) or equal seals will adhere to the shaft after assembly and must be replaced if

removed from the shaft. The (Type 680) metal bellows seals or equal use O-rings to seal against the shaft and may be reused if their condition does not dictate replacement.

The rubber bellows (Type 43) or equal seals are friction-driven which makes adhesion to the shaft a necessity. The metal bellows (Type 680) seals or equal are positive driven and locked to the shaft with set screws that must be loosened to remove seal.

4-22. Packing. It is sound practice to always replace packing (6900) whenever the pump is disassembled.

4-23. Rotor

1. To check for excessive rotor (5000) wear, measure the rotor crest-to-crest diameter (see Figure 4-4) and compare with the following chart:

Rotor Size	Standard Crest-to-Crest Dia. (inches)
A	.886
B	1.061
C	1.327
D	1.671
E	2.100
F	2.676
G	3.428
H, J, K	4.015

The rotor size is designated by the third letter in the Model Number (i.e., A2ECDQ3AAA).

2. If the measured crest-to-crest diameter is within .010 in. of the standard value, the rotor is reusable provided that:

- the rotor pin holes are not excessively worn.
- the rotor surface is not cracked, pitted or deeply grooved (.030 in. or more).

3. Rotors with crest-to-crest diameters greater than .010 in. under the standard value should generally be replaced.

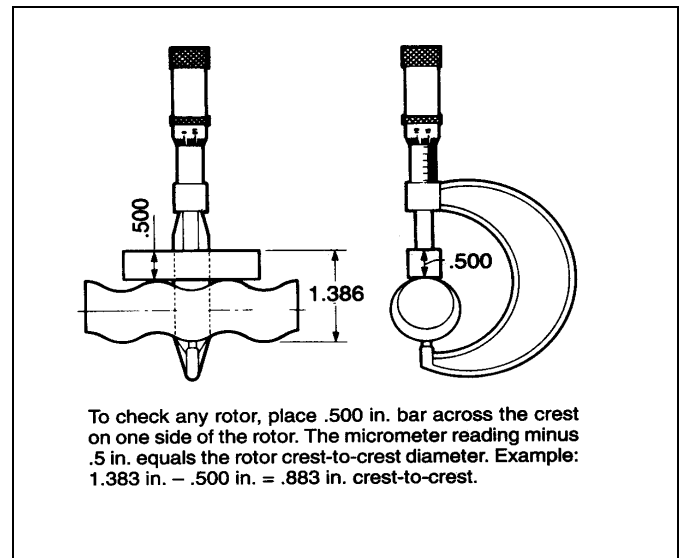

Figure 4-4. Measuring Rotor Diameter

4-24. Stator. The best indication of stator wear (6500) and the need for replacement is a drop in pump performance. Stators with interior surfaces that are pitted, grooved or gouged should also be replaced.

4-25. All Other Parts. Check for cracks, excessive wear, damage to threaded holes, burrs, etc. Replace as necessary. Replace O-rings (K) and all gaskets (1200, 1210, and 1220) at each disassembly and reassembly.

4-26. ASSEMBLY

Bearing Housing (One-Piece Shaft Models)

NOTE: For two-piece shaft models, go to 4-27. For close-coupled models, go to 4-28.

- Slide stuffing box (1000) on to drive shaft (6000), large flanged end first.
- Slide packing gland (0900) on to shaft so that the round portion fits into the stuffing box.
- Place slinger ring (6800) on shaft, adjacent to the packing gland.
- Place bearing housing snap ring (G) on the shaft.

4-26a. Ball Bearing Models

- Press sealed bearing (E) on drive shaft.
- Install shaft snap ring (F) in groove on shaft. Seat bearing against snap ring.
- Install second shaft snap ring.
- Press second sealed bearing on shaft and seat against snap ring.
- If not already in place, install bearing housing snap ring (G) in groove inside drive end of bearing housing (0100).

6) Place assembled drive shaft into bearing housing. Secure by inserting second bearing housing snap ring in groove in stuffing box end of bearing housing.

4-26b. Tapered Roller Bearing Models

1) Press grease seal (B) into grease seal housing (0700) and place assembly on shaft with chamfered side of grease seal housing facing keyway end of shaft.

2) Pack the bearings (D) **thoroughly** with grease, Mobilux EP2 or equal.

3) Place bearing cup on shaft and press bearing cone on shaft approximately .150 in. beyond snap ring groove.

4) Place grease retainer (0500) on shaft and install shaft snap ring (F) in groove on shaft.

5) Seat bearing and grease retainer against snap ring.

6) Install second shaft snap ring in groove on shaft and place second grease retainer on shaft.

7) Press bearing cone on shaft, and seat bearing and grease retainer against snap ring.

8) Fill grease seal housing with grease.

9) Slide drive shaft assembly into bearing housing. Secure by inserting bearing housing snap ring (G) in groove in bearing housing at rear of stuffing box area.

10) Fill area around the bearing in the drive end of the bearing housing with grease.

11) Complete bearing assembly by sliding bearing cup into bearing housing.

12) Press grease seal in bearing cover (0300) and place bearing cover on shaft. Secure with bearing cover screws and lock washers (A). (see Section 4-29.)

4-27. ASSEMBLY (Two-Piece Shaft Models)

NOTE: For close-coupled models, go to 4-28.

4-27a. Ball Bearing Models

1) Press sealed bearing on drive shaft.

2) Install shaft snap ring in groove on shaft. Seat bearing against snap ring.

3) Install second shaft snap ring.

4) Press second sealed bearing on shaft and seat against snap ring.

5) If not already in place, install bearing housing snap ring in groove inside stuffing box end of bearing housing.

6) Place assembled drive shaft into bearing housing. Secure by inserting second bearing housing snap ring

in groove in drive end of bearing housing. Proceed to 4-30.

4-27b. Tapered Roller Bearing Models

1) Install bearing housing retaining ring in bearing housing groove.

2) Press grease seal into grease seal housing and assemble in housing with chamfered side of grease seal housing facing bearing location.

3) Slide bearing cup into the bearing housing against the seal housing.

4) Press bearing cone on shaft approximately .150 in. beyond snap ring groove.

5) Place grease retainer on shaft and install shaft snap ring in groove on shaft.

6) Seat bearing and grease retainer against snap ring.

7) Install second shaft snap ring in groove on shaft and place second grease retainer on shaft.

8) Press bearing cone on shaft, and seat bearing and grease retainer against snap ring.

9) Fill grease seal housing with grease.

10) Slide drive shaft assembly into bearing housing.

11) Fill area around the bearing in the drive end of the bearing housing with grease.

12) Complete bearing assembly by sliding bearing cup into bearing housing.

13) Press grease seal in bearing cover (0300) and place bearing cover on shaft. Secure with bearing cover screws and lock washers Proceed to 4-29.

4-28. Close-Coupled Models - Pinned versions are similar to two piece shaft versions. Locking ring version is listed below.

1) Place locking ring on drive shaft with key clearance slot aligned with keyslot in drive shaft.

2) Mount drive to the drive adaptor (0100) using four bolts, lock washers, and nuts.

3) Install drive shaft assembly into the drive adaptor while coupling drive shaft to output shaft of drive.

4) **Rotate locking ring 90 degrees and secure one set screw over the key and the other set screw at 180 degrees through the hole in the drive shaft, securing on the output shaft of the drive.**

4-29. Adjusting Bearing End Play (Tapered Roller Bearings Only)

1. Tighten bearing cover screws around bearing cover firmly, to the point the shaft will not turn. (Screws should be tightened evenly, opposite each other.)

2. Measure the gap between the bearing cover and the bearing housing.
3. Remove bearing cover and add shims (6700) to equal gap measured in step 2 plus an additional .010 in.
4. Install bearing cover with shims and tighten screws evenly, opposite each other.
5. Tap lightly on the shaft head or end using a soft mallet. Rotate shaft to "free up" assembly. You should be able to rotate the shaft by hand.
6. Shims may be added or subtracted to get the proper setting.
7. Slide the rubber pin retainer on the drive shaft pushing past the pin hole.

4-30. Intermediate Drive Shaft Installation (Mechanical Seal Pumps Proceed to 4-30a.)

1. Position the packing in the stuffing box and install the gland studs, if removed.
2. Position the stuffing box in the bearing housing, sliding the packing gland on packed models onto the gland studs. Rotate the stuffing box so that the zerk fitting is on the side.
3. Install the intermediate shaft seal ring (2200) on the intermediate shaft.
4. Insert the intermediate shaft through the stuffing box, seating the end of the intermediate drive shaft into the drive shaft. Rotate the shafts to align the pin holes and insert the pin.
5. Slide the rubber pin retainer in place on the drive shaft over the pin.

4-30a. Mechanical Seal Installation (Single Seal)

1. Install the stationary component (seat and O-ring) of mechanical seal (6950) in seat of seal retainer (1000).
2. Position the seal housing in the bearing housing (1).
3. Slide the rotating component (spring and rotating seat) onto the drive shaft. It may be necessary to wipe a small amount of lubricant around inside diameter of rotating component.
4. Lock mechanical seal set screws onto shaft if mechanical seal is positively driven, locating the end of the seal flush with the end of the drive shaft.
5. Install the intermediate shaft O-ring (2200) on the intermediate shaft.

6. Insert the intermediate shaft into the drive shaft. Rotate the shafts to align the pin holes and insert the

drive shaft pin, compressing the mechanical seal spring on single spring friction drive seals.

7. Locate slinger/pin retainer on the shaft covering the pin.

4-30b. Mechanical Seal Installation (Double Seal)

1. Press the stationary seat into the gland for a double seal installation, taking care not to damage the face. Put gland on shaft with care.
2. Install the seal on the shaft.
3. On double seal models the seal housing (modified packing stuffing box) is slid on the shaft, with stationary seat fitted into place. The seal assembly is then compressed by bolting the gland to the seal housing. This will bring the faces into contact.
4. Install the intermediate shaft O-ring (2200) on the intermediate shaft.
5. Insert the intermediate shaft into the drive shaft. Rotate the shafts to align the pin holes and insert the drive shaft pin.
6. Locate the slinger/pin retainer on the shaft covering the drive shaft pin.

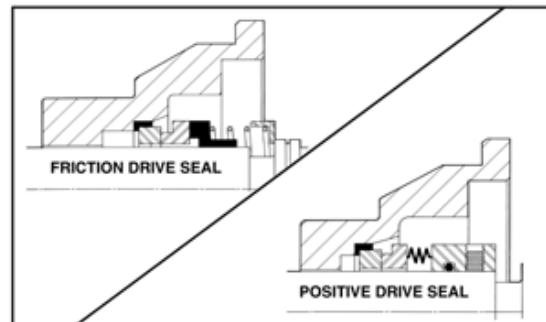

Cross Section of Typical Single Seal Installations

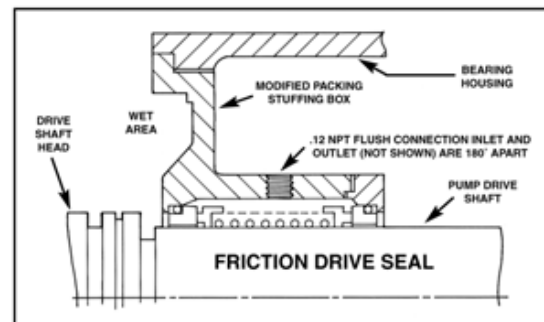

Cross Section of Typical Double Seal Installation

4-31. Connecting rod or Auger Assembly

1. Install universal joint seal (6400) on connecting rod (or auger assembly) (6200), making sure the raised ridge inside the universal joint seal is placed in the matching groove on the connecting rod.

2. Fold other end of seal back towards center of connecting rod.
3. Spread head snap ring (J) ends and place on drive shaft between drive shaft head and stuffing box.
4. Place head O-ring (K) in matching groove on drive shaft head.
5. Fill shaft head with a good grade of EP (Extreme Pressure) lithium soap-base grease such as Shell Alvania EP1 (Shell Oil Co.), Texas Refinery Corp. 880 Crown and Chassis grease, or equivalent.
6. Slide retaining ring (6100), chamfered end first, over universal joint seal on to connecting rod.
7. Place end of connecting rod in drive shaft head and align holes. Coat drive pin (6300) with grease and insert in pin hole.
8. Slide retaining ring back over the universal joint seal and place on the drive shaft head, exposing universal joint seal groove.
9. Unfold the seal and snap the lip in matching groove on the shaft head.
10. Slide the retaining ring back, compressing the lip of the seal and exposing the snap ring groove on the shaft head. Install snap ring in groove to secure the retaining ring.
11. Using similar procedures outlined in previous steps 1 through 10, attach rotor (5000) to connecting rod or auger assembly.

4-32. Suction Chamber

1. Screw drain plug (N or P) into bottom of suction chamber.
2. Before installing the suction chamber (1100), make sure that the stuffing box and packing gland bolt holes are in a horizontal plane parallel to the pump base. If not, turn stuffing box in either direction until bolt holes are horizontal.
3. Place suction chamber gasket (1220) over projection on end of suction chamber.
4. Slide suction chamber over the rotor and connecting rod or auger assembly and fasten to the bearing housing.

On standard models, fastening is by means of suction chamber bolts and lock washers (M). On open throat models, the suction chamber slides onto studs (O) protruding from the bearing housing and is secured with nuts and lock washers.

4-33. Stator

1. Put stator gasket (1200) in place in the exposed end of suction chamber.

Note: 1. Before installation of stator, lubricate rotor and/or inside of stator with water or glycerine to facilitate installation. Be sure to use a lubricant that is compatible with the stator elastomer.

2. On four-stage models, a stator adaptor (1500) will be used. Place stator adaptor gasket (1210) in suction housing, install stator adaptor and place stator gasket in stator adaptor before installing stator.

2. Slide stator clamp rings (1800) on both ends of the stator (6500) and secure in position with retaining rings (R).

3. Slide stator (6500) over the rotor.

Note: Turning the rotor counterclockwise while inserting into stator makes assembly easier.

4. If the stator is firmly seated against the stator gasket in the suction housing recess, align the holes in clamp ring with the threaded holes in the suction housing. Thread the four hex head bolts (M) with lock washers through hole in clamp ring into the threaded holes. Tighten bolts evenly.

4-34. Stator Support/Discharge Flange Assembly

1. Place top of stator support over stator. Fasten to bottom half of stator support using hex head bolts.

Note: Some smaller models have a fabricated steel support that attaches to the stator clamp ring at the discharge end.

2. Place stator gasket in recess in discharge flange and position discharge flange on end of stator. Align holes in stator clamp ring with threaded holes in discharge flange. Install and evenly tighten the hex bolts.

4-35. Packing

1. Lubricate inside diameter of packing (6900) in accordance with manufacturer's instruction.
2. Install 4 rings of packing in stuffing box, staggering joints at 90 degrees intervals. The lantern ring should be in between with 2 rings on each side.

Note: On new packing, typically 4 rings are installed with a 5th being added after adjustments.

3. Secure packing gland with packing gland screws, lock washer and nuts (H).

4. Adjust packing per Section 4-3.

4-36. Pump Connections

1. Install shaft key (I) in drive shaft keyway for installation of coupling or sheave.

2. Connect piping to pump.

3. Check complete pump installation per INSTALLATION instructions. (Sections 2-1 through 2-9)

4. Review OPERATION instructions per Sections 3-1 through 3-4.

4-37. STORAGE

4-37a. Short-Term Storage. Storage of six months or less will not damage the pump. However, to ensure the best possible protection, the following is advised:

1. Store pump inside whenever possible or cover with some type of protective covering. Do not allow moisture to collect around pump.

2. Remove drain plug to allow the pump body to drain and dry completely.

3. See drive manufacturer's instructions for motor and/or drive storage.

4. Every 2 or 3 weeks, rotate the pump manually a few revolutions to avoid a "set" condition of rotor in stator elastomer. This will prevent hard starting and excessive torque requirements when pump is again put into operation.

5. See OPERATION Sections 3-1 through 3-4 before start-up. Be sure all lubricants are in good condition.

4-37b. Long-Term Storage. If pump is to be in storage for more than six months, perform the above short-term storage procedures with the exception of Step 4. In its place, it is suggested that the stator be removed to avoid developing a "set" condition. In addition:

1. Apply rust inhibitor to all unpainted cast iron and machined carbon steel surfaces.

2. Remove drive belts if applicable.

4-38. STANDARD PACKING SPECIFICATION

Packing is of the braided, non-asbestos type, fully impregnated throughout with lubricant and graphite. Service is to be for medium-to-high-speed rotary shaft applications (to 10 mps or 2000 fpm) and excellent for use in low or medium pressure pumps as well as valves. Temperatures to 350 degrees (175 degrees C). pH range: 4-10. Recommended packing grease Mobilux MPG 2 or equal.

4-39. RECOMMENDED SPARE PARTS

The Moyno 1000 pump has been designed and built to minimize overall operating costs. All wearable parts are replaceable. A recommended inventory of spare parts is dependent upon the application and the importance of continued operation.

To minimize down time, we recommend the following quantities of spare parts be stocked.

- 1 – Rotor
- 2 – Head O-Rings
- 2 – Head Snap Rings
- 1 – Stator
- 2 – Stator Gaskets
- 1 – Connecting Rod
- 2 – Universal Joint Seals*
- 2 – Drive Pins
- 1 – Packing Set

*For models utilizing a one-piece seal, a single universal joint seal should be stocked.

The above is a suggested list. For further assistance in determining what you will need for your application, contact your Moyno representative.

4-40. HOW TO ORDER SPARE PARTS

When ordering spare parts, the pump model and serial number should be supplied. The part numbers and letters shown on the exploded views apply to all models.

The following information must be supplied when ordering parts:

- 1. Pump model number
- 2. Manufacturer's serial number
- 3. Refer to the Exploded Views (Section 4-43 through 4-47) to locate the parts needed.
- 4. Refer to your particular pump model in Section 4-48 and identify the actual part number needed.

CLAMP RING BOLT CHART

Ref. No.	Description	QTY	A2A B2A A1B B1B A2B B2B D4B E4B	A4A B4A	A4B B4B	A1C B2C A2C D4C B1C E4C	A4C B4C	A1D A1E D4D A2D A2E E4D B1D B1E D4E B2D B2E E4E	A4D B4D	A4E B4E
Suction End Bolts		[4]	M10x30 (AA076)	M12x50 (AA105)	M12x55 (AA106)	M12x35 (AA102)	M12x55 (AA106)	M12x40 (AA103)	M16x70 (AA159)	M16x80 (AA161)
Lockwashers		[4]	M10 (AE075)	M12 (AE100)	M12 (AE100)	M12 (AE100)	M12 (AE100)	M12 (AE100)	M16 (AE150)	M16 (AE150)
Discharge End Bolts		[4]	M10x30 (AA076)		M16x35 (AA162)			M12x35 (AA102)		
Lockwashers		[4]	M10 (AE075)		M16 (AE150)			M12 (AE100)		
Discharge End Bolts		[1]		M12x30 (AA101)		M12x30 (AA101)				
Lockwashers		[1]		M12 (AE100)		M12 (AE100)				
Discharge End Bolts		[3]		M12x35 (AA102)		M12x35 (AA102)				
Lockwashers		[3]		M12 (AE100)		M12 (AE100)				
Discharge End Bolts		[8]					M12x35 (AA102)		M16x40 (AA153)	M16x45 (AA154)
Lockwashers		[8]					M12 (AE100)		M16 (AE150)	M16 (AE150)
Ref. No.	Description	QTY	A1F A2F B2F B1F D4F	A4F	A1G B1G A2G D4G	A1H A1J A2H A2J D4H A1K	C1E C2E	C1F C2F	C1G C2G	C1H C2H C2J C1J C1K
Suction End Bolts		[4]	M16x45 (AA154)	M20x90 (AA188)	M16x45 (AA154)	M20x55 (AA181)	M12x35 (AA102)	M16x40 (AA153)	M16x40 (AA153)	M20x45 (AA179)
Lockwashers		[4]	M16 (AE150)	M20 (AE175)	M16 (AE150)	M20 (AE175)	M12 (AE100)	M16 (AE150)	M16 (AE150)	M20 (AE175)
Discharge End Bolts		[4]	M16x35 (AA152)		M16x40 (AA153)	M20x45 (AA179)	M12x35 (AA102)	M16x35 (AA152)	M16x40 (AA153)	M20x45 (AA179)
Lockwashers		[4]	M16 (AE150)		M16 (AE150)	M20 (AE175)	M12 (AE100)	M16 (AE150)	M16 (AE150)	M20 (AE175)
Discharge End Bolts		[8]		M20x50 (AA180)						
Lockwashers		[8]		M20 (AE175)						

4-41. STANDARD HARDWARE LIST - STANDARD AND OPEN THROAT MODELS

NOTE: It is suggested that the standard hardware below be purchased at your local hardware outlet. Items can be purchased from Moyno Inc. The number in () is Moyno's reference number only.

MODELS										
Ref. No. Description []	Qty	A2A	A1B A2B D4B	D4C A1C A2C A4A	A4B	D4D A1D A2D	D4E A1E A2E A4C C1E C2E	D4F A1F A2F A4D C1F C2F	D4G A1G A2G A4E C1G C2G	A1K A1H C1H A2H C2H D4H C1J A1J C2J A2J C1K
A. Bearing Cover Screw (Steel hex head socket, ISO metric fully threaded) Lock Washer*			----			M8x1.25x30 [4] (AM051) M8 (4) (AE050)		M10x1.5x30 [4] (AM078) M10 (4) (AE075)		M10x1.5x30 [6] (AM078) M10 (6) (AE075)
B. Grease Seal (Lip contact sealing with press fit O.D.)			----			48 O.D.x32 I.D. [2] (DA061)		68 O.D.x45 I.D. [2] (DA086)		78 O.D.x55 I.D. [1] (DA097) 78 O.D.x60 I.D. [1] (DA098)
C. Name Plate Drive Screw [4] (Steel, round head, type U)			No. 2 x 3" (AN005)			No. 2 x 3" (AN005)		No. 2 x 3" (AN005)		No. 2 x 3" (AN005)
D. Tapered Roller Bearing [2]						LM67048/LM67010 (BL005)		25580/25520 (BL010)		JM207049/JM207010 (BL015)
E. Ball Bearing [2]			6205 Dbl. Seal (BD005)			----		----		----
F. Shaft Snap Ring [2] (Basic external retaining ring)			Sft. ϕ 25 (EB004) 23.1 I.D.x1.1w			Sft. ϕ 32 (EB012) 29.6 I.D.x1.3w		Sft. ϕ 45 (EB024) 41.6 I.D.x1.6w		Sft. ϕ 55 (EB031) 50.6 I.D.x2.0w
G. Bearing Housing Snap Ring [2] (Basic internal retaining ring)			52 Bore (EA015) 57.9 O.D.x2.0w [2]			58 Bore (EA022) 64.4 O.D.x2.0w [1]		82 Bore (EA035) 91.1 O.D.x2.8w [1]		95 Bore (EA041) 105.6 O.D.x2.8w [1]
H. Packing Gland Screw [2] Packing Gland Stud*** [2] Hex Nut [2] (Steel, ISO metric coarse thread) Lock Washer* [2]			M6x1.0x45 (AL029) 4220416001 M6x1 (AB025)			M8x1.25x55 (AL056) 4220417001 M8x1.25 (AB050)		M10x1.5x60 (AL082) 4220418001 M10x1.5 (AB075)		M10x1.5x70 (AL084) 4220418001 M10x1.5 (AB075)
I. Shaft Key [1]			M6 (AE025)			M8 (AE050)		M10 (AE075)		M10 (AE075)
J. Head Snap Ring [2] (Basic external retaining ring)H			6x6x40 (GA007)			8x7x70 (GA012)		12x8x80 (GA021)		14x9x100 (GA024)
K. Head O-Ring [2]			Sft. ϕ 28 25.8 I.D.x1.3w (EB007)	Sft. ϕ 35 32.3 I.D.x1.3w (EB015)	Sft. ϕ 40 36.75 I.D.x1.6w (EB020)	Sft. ϕ 48 44.4 I.D.x1.6w (EB027)	Sft. ϕ 65 60.4 I.D.x2.0w (EB036)	Sft. ϕ 82 76.4 I.D.x2.4w (EB045)		Sft. ϕ 100 92.5 I.D.x2.8w (EB049)
L. Clamp Ring Bolt (Steel hex, ISO metric bolt coarse thread) Lock Washer*			25 I.D.x 2.65 ϕ (CA137)	30 I.D.x 2.65 ϕ (CA141)	34.5 I.D.x 2.65 ϕ (CA145)	40.0 I.D.x 3.55 ϕ (CA175)	58.0 I.D.x 3.55 ϕ (CA188)	75.0 I.D.x 3.55 ϕ (CA197)		90 I.D.x3.55 ϕ (CA228)
M. Suction Chamber Bolt [4] (Steel hex head, ISO metric coarse thread) Lock Washer* [4]			RST-162 (EC022)	RS-187 (EC028)	RS-236 (EC034)	RS-287 (EC039)	RS-343 (EC046)	RS-450 (EC055)	RS-551 (EC060)	RS-662 (EC065)
N. Drain PlugH [1]			----			M10x40 (AL078) M10 (AE075)	M10x50 (AL080) M10 (AE075)	M16x80 (AL161) (A4D & A4E M10x50) (AL080) M16 (AE150)	M16x80 (AL161) M16 (AE150)	M20x90 (AL188) M20 (AE175)
T. Optional Insp. Plate Bolt Lock Washer*			----			M6x16 (AA023) M6 (AE025)	M8x20 (AA049) M8 (AE050)	M10x25 (AA075) M10 (AE075)		M10x25 (AA075) M10 (AE075)
STANDARD MODELS ONLY										
M. Suction Chamber Bolt [4] (Steel hex head, ISO metric coarse thread) Lock Washer* [4]			M10x1.5x35 (AA077)			M10x1.5x40 (AA078)		M16x2x55 (AA156)		M20x2.5x70 (AA184)
N. Drain PlugH [1]			M10(AE075)			M10 (AE075)		M16 (AE150)		M20 (AE175)
O. Suction Chamber Stud [4] (Steel, double end ISO metric coarse thread) Hex Nut [4] (Steel, ISO metric coarse thread) Lock Washer* [4]			.5 NPT (FB012)			.5 NPT (FB012)		.75 NPT (FB018)		.75 NPT (FB018)
OPEN THROAT MODELS ONLY										
P. Drain PlugH [1]			----			M10x1.5x30 (AS076) M10x1.5 (AB075) M10 (AE075)		M16x2x45 (AS154) M16x2 (AB150) M16 (AE150)		M20x2.5x50 (AS180) M20x2.5 (AB175) M20 (AE175)

* All lock washers are steel, single coil, helical spring.

H Stainless steel required on stainless steel models.

Change the third digit of the part number to "5", i.e., Drain Plug (FB512).

** 4-stage models use the same stator rings as 2-stage models of the same element size.

*** Stuffing boxes with tapped holes use the studs.

LEGEND:

O.D. = Outer Diameter

I.D. = Inner Diameter

ϕ = Diameter

W = Wide

* = Inches

NPT = American National Standard

Taper Pipe

Sft = Shaft

4-42. STANDARD HARDWARE LIST – CLOSE-COUPLED MODELS

MODELS											
Ref. No.	Qty []	B2A	E4B B1B B2B	B1C B4A B2C E4C	B4B	B1D B2D E4D	B1E B4C B2E E4E	B1F B2F B4D	B1G B2G B4E	B4F B4G	B1H, B2H B1J, B2J B1K, B2K B1L
C. Name Plate Drive Screw (Steel, round head, type U)	[2]		No. 2 x 3" (AN005)			No. 2 x 3" (AN005)		No. 2 x 3" (AN005)			No. 2 x 3" (AN005)
D. Locking Ring Set Screw (Hex socket flat Point)	[2]		M6x1.0x6 (AK079)			M6x1.0x8 (AK180)		M8x1.25x10 (AK106)			
H. Packing Gland Screw Packing Gland Stud*** Hex Nut (Steel, ISO metric coarse thread) Lock Washer*	[2] [2] [2] [2]		M6x1.0x45 (AL029) 4220416001 M6x1.0 (AB025) M6 (AE025)			M8x1.25x55 (AL056) 4220417001 M8x1.25 (AB050) M8 (AE050)		M10x1.5x60 (AL082) 4220418001 M10x1.5 (AB075) M10 (AE075)			M10x1.5x70 (AL084) 4220418001 M10x1.5 (AB075) M10 (AE075)
J. Head Snap Ring (Basic external retaining ring)H	[2]	Sft. ϕ 28 25.8 I.D.x1.3w 5100-112 (EB007)	Sft. ϕ 35 32.3 I.D.x1.3w 5100-137 (EB015)		Sft. ϕ 40 36.75 I.D.x1.6w 5100-156 (EB020)	Sft. ϕ 48 44.4 I.D.x1.6w 5100-187 (EB027)	Sft. ϕ 65 60.4 I.D.x2.0w 5100-255 (EB036)	Sft. ϕ 82 76.4 I.D.x2.4w 5100-325 (EB045)			Sft. ϕ 100 92.5 I.D.x2.8w (EB049)
K. Head O-RingHH	[2]	23.6 I.D.x 2.65 ϕ (CA137)	30 I.D.x 2.65 ϕ (CA141)		34.5 I.D.x 2.65 ϕ (CA145)	40.0 I.D.x 3.55 ϕ (CA175)	58.0 I.D.x 3.55 ϕ (CA188)	75.0 I.D.x 3.55 ϕ (CA197)			90 I.D.x3.55 ϕ (CA228)
L. Clamp Ring Bolt (Steel hex, ISO metric coarse thread) Lock Washer*		See Chart on Page 11									
M. Suction Chamber Bolt (Steel hex head, ISO metric coarse thread) Hex Nut Lock Washer*	[4] [4] [4]		M10x1.5x50 (AA080)			M10x1.5x50 (AA080)		M16x2x75 (AA160)			M20x2.5x70 (AA184)
N. Drain PlugH	[1]		.5 NPT (FB012)			.5 NPT (FB012)		.75 NPT (FB018)			.75 NPT (FB018)
R. Stator Ring	[2]	RST-162 (EC022)	RS-187 (EC028)	RS-243 (EC034)	RS-281 (EC039)	RS-343 (EC046)	RS-450 (EC055)	RS-551 (EC060)			RS-662 (EC065)
S. Stator Support Bolt (Steel hex nut, ISO metric coarse thread) Lock Washer	[2] [2]		----		M10x40 (AL78)	M10x50 (AL 080)	M16x80 (AL161) (A4D & A4E M10x50) (AL080) M16 (AE150)		M16x80 (AL161)		M20x90 (AL188) M20 (AE175)
T. Optional Insp. Plate Bolt Lock Washer			----				M6x16 (AA023) M6 (AE025)	M8x20 (AA049) M8 (AE050)	M10x25 (AA075) M10 (AE075)		M10x25 (AA075) M10 (AE075)

* All lock washers are steel, single coil, helical spring.
H Stainless steel required on stainless steel models (XX5XX).
HH Requires fluoroelastomer (CFXX) on pumps with RF stators
** 4-stage models use the same stator rings as 2-stage models of the same element size.
*** Stuffing boxes with tapped holes use the studs.

LEGEND:
O.D. = Outer Diameter
I.D. = Inner Diameter
 ϕ = Diameter
W = Wide

* = Inches
NPT = American National Standard
Taper Pipe
Sft = Shaft

4-43. EXPLODED VIEWS

4-44. STANDARD MODEL – BALL BEARING DESIGN DRIVE END

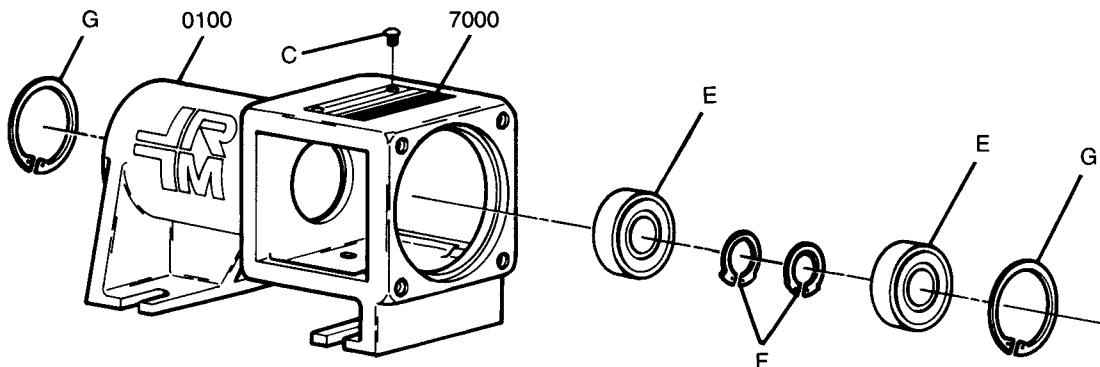

4-45. STANDARD MODEL – ROLLER BEARING DESIGN DRIVE END

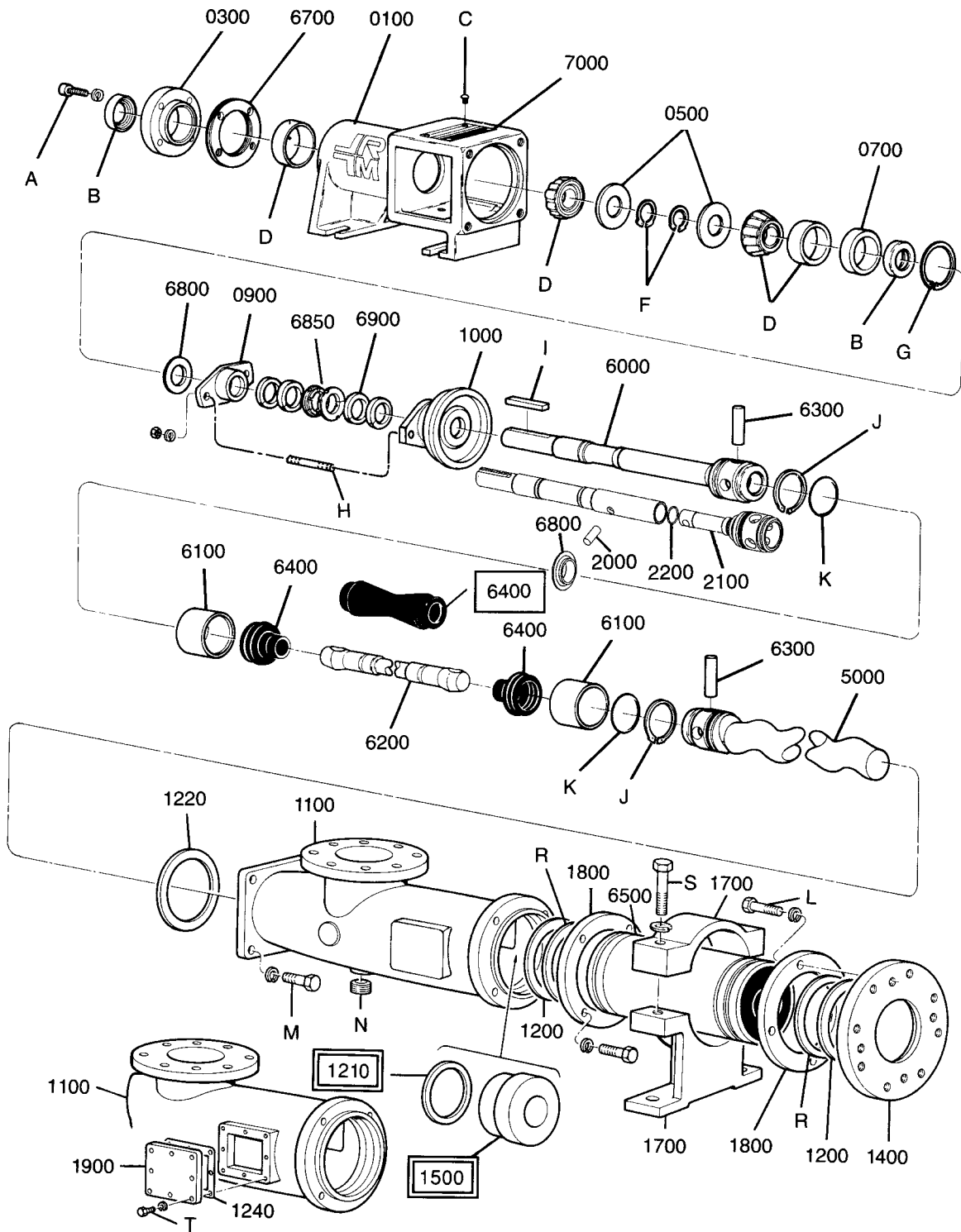

= Used on Models A4A, A4B, A4C, A4D, A4E, A4F

= Used on Models A1B, A1C, A1D, A2A, A2B, A2C, A2D, A4A, A4B, D4B, D4C, D4D

4-46. CLOSED-COUPLED MODELS

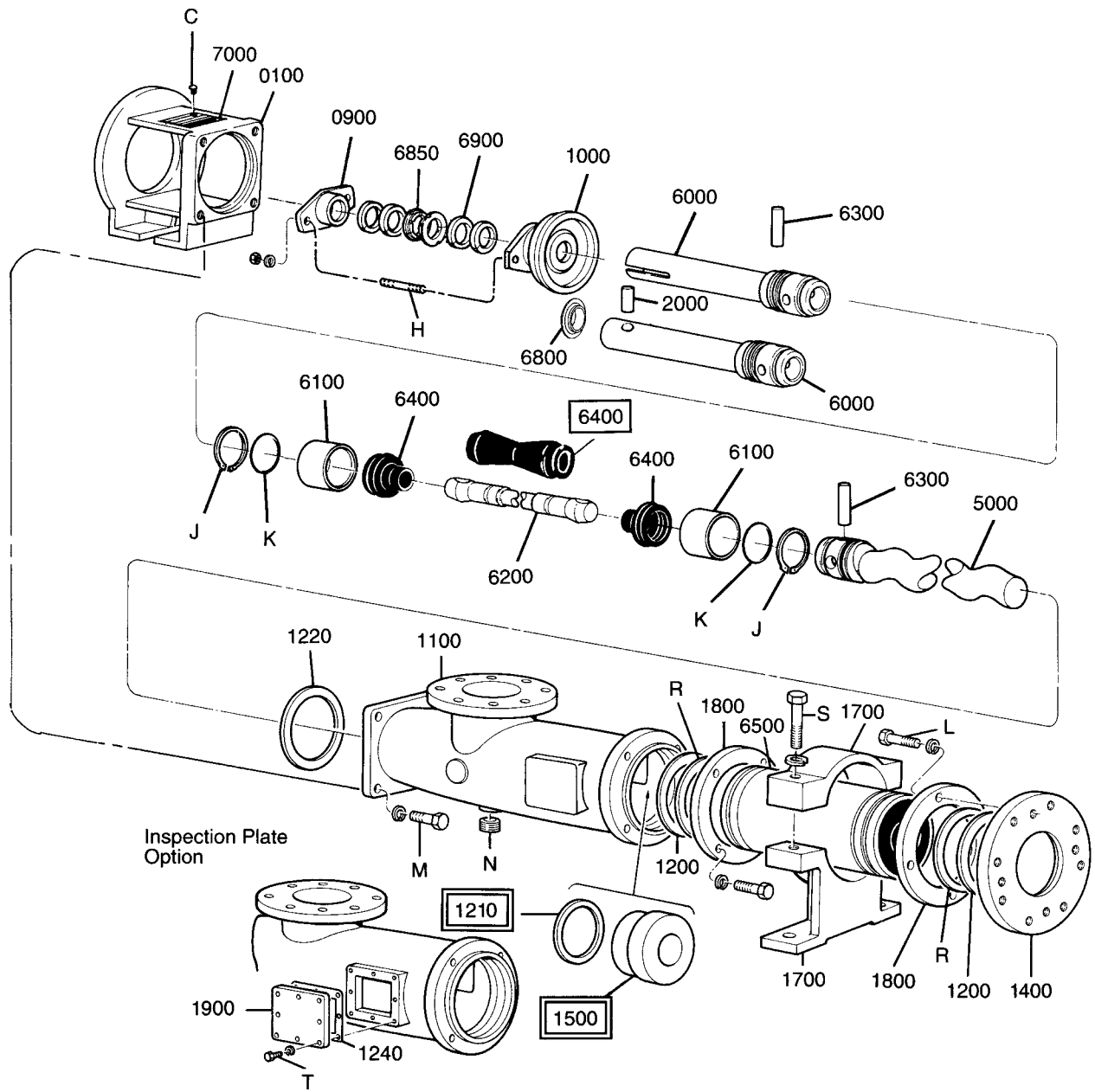

 = Used on Models B4A, B4B, B4C, B4D, B4E

 = Used on Models B1B, B1C, B1D, B2A, B2B, B2C, B2D, B4A, B4B, E4B, E4C, E4D,

4-47. OPEN THROAT MODELS

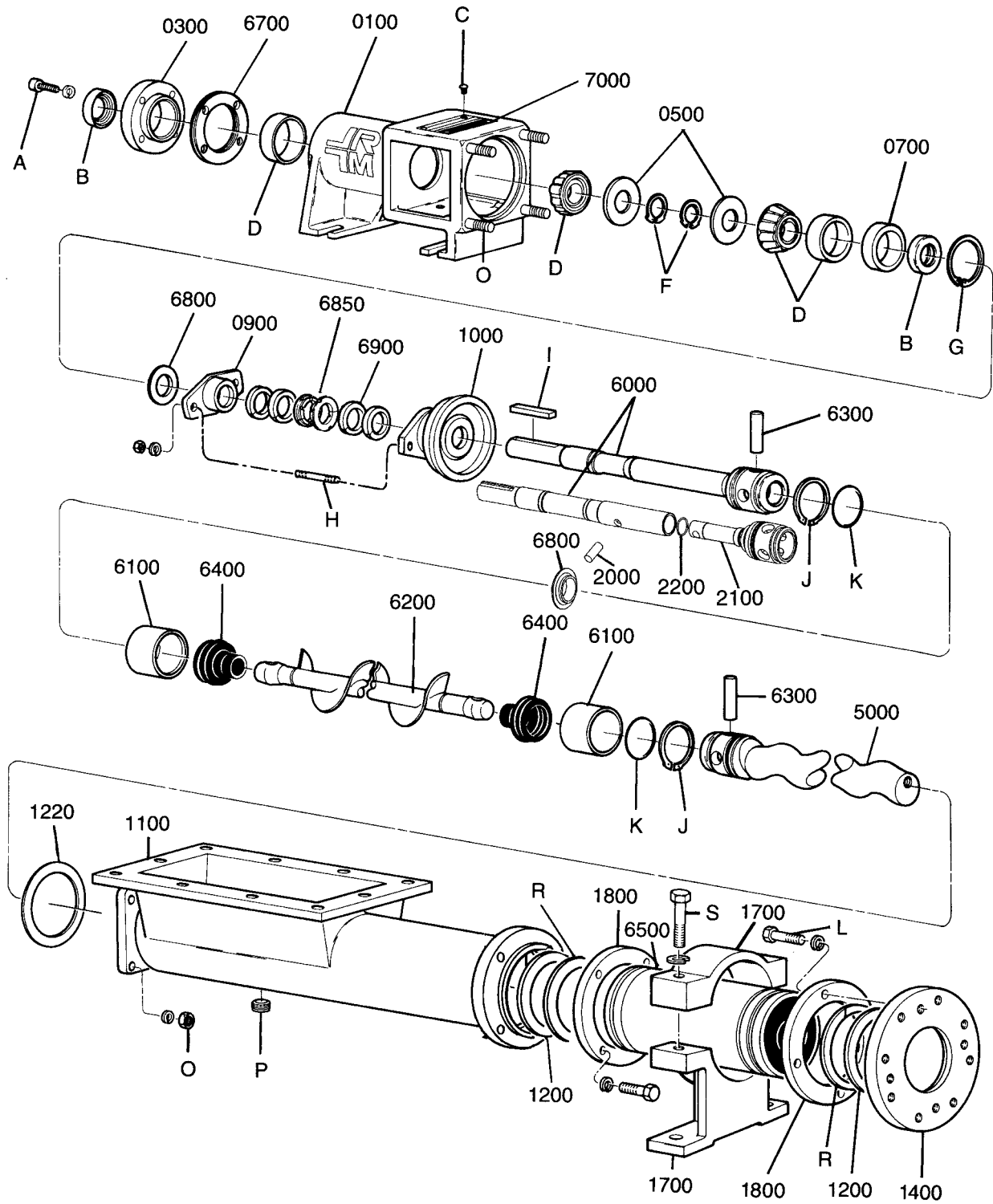

4-48. PARTS LISTS

REF. DESCRIPTION	TYPE	A2A PART NO.	A1B PART NO.	A2B PART NO.	A1C PART NO.	A2C PART NO.
0100 BEARING HOUSING	CD/SS	CC A2A0110	CC A2A0110	CC A2A0110	CC A2A0110	CC A2A0110
0900 PACKING GLAND	CD/SS	SC A2A0910	SC A2A0910	SC A2A0910	SC A2A0910	SC A2A0910
1000 STUFFING BOX	CD SS	CC A2A1010 SC A2A1010	CC A2A1010 SC A2A1010	CC A2A1010 SC A2A1010	CC A2A1010 SC A2A1010	CC A2A1010 SC A2A1010
1000 SEAL HOUSING	* ** CD/SS CD/SS	SC A2A1011 4240833007	SC A2A1011 4240833007	SC A2A1011 4240833007	SC A2A1011 4240833007	SC A2A1011 4240833007
1100 SUCTION CHAMBER	CD SS	CC A2A1110 SC A2A1110	CC A1B1110 SC A1B1110	CC A1B1110 SC A1B1110	CC A1C1110 SC A1C1110	CC A1C1110 SC A1C1110
1200 STATOR GASKET	Q/R F B	GG A2A1200 GF A2A1200 GB A2A1200	GG A1B1200 GF A1B1200 GB A1B1200	GG A1B1200 GF A1B1200 GB A1B1200	GG A1C1200 GF A1C1200 GB A1C1200	GG A1C1200 GF A1C1200 GB A1C1200
1220 SUCTION CHAM. GASKET	Q/R F B	GG A2A1220 GF A2A1220 GB A2A1220	GG A2A1220 GF A2A1220 GB A2A1220	GG A2A1220 GF A2A1220 GB A2A1220	GG A2A1220 GF A2A1220 GB A2A1220	GG A2A1220 GF A2A1220 GB A2A1220
1400 DISCHARGE FLANGE	CD SS	MS A2A1410 SS A2A1410	MS A1B1410 SS A1B1410	MS A1B1410 SS A1B1410	MS A1C1410 SS A1C1410	MS A1C1410 SS A1C1410
1700 STATOR SUPPORT	CD/SS	MS A2A1710	MS A2A1710	MS A2A1710	MS A1C1710	MS A1C1710
1800 CLAMP RING	CD/SS	MS A2A1810	MS A1B1810	MS A1B1810	MS A1C1810	MS A1C1810
2000 SHAFT PIN	CD/SS	4220487017	4220487017	4220487017	4220487017	4220487017
2100 INTERMEDIATE SHAFT	CD SS	4250392001 4250392017	4250392001 4250392017	4250392001 4250392017	4250393001 4250393017	4250393001 4250393017
2200 SEAL RING	Q/R F B	3207902206 3207905206 3207904206	3207902206 3207905206 3207904206	3207902206 3207905206 3207904206	3207902206 3207905206 3207904206	3207902206 3207905206 3207904206
5000 ROTOR	CD SS	TS A2A5000 SS A2A5000	TS A1B5000 SS A1B5000	TS A2B5000 SS A2B5000	TS A1C5000 SS A1C5000	TS A2C5000 SS A2C5000
6000 DRIVE SHAFT	CD SS	AS A2A6000 SS A2A6000	AS A2A6000 SS A2A6000	AS A2A6000 SS A2A6000	AS A1C6000 SS A1C6000	AS A1C6000 SS A1C6000
6000 DRIVE SHAFT (2-PIECE OPTION)	CD SS	4250378001 4250378017	4250378001 4250378017	4250378001 4250378017	4250378001 4250378015	4250378001 4250378015
6100 RETAINING RING	CD/SS	ST A2A6100	ST A2A6100	ST A2A6100	ST A1C6100	ST A1C6100
6200 CONNECTING ROD	CD/SS	AS A2A6200	AS A2A6200	AS A2A6200	AS A1C6200	AS A1C6200
6300 DRIVE PIN	CD/SS	TR A2A6300	TR A2A6300	TR A2A6300	TR A1C6300	TR A1C6300
6400 JOINT SEAL	Q/R F/B	RD A2A6400 RF A2A6400	RD A2A6400 RF A2A6400	RD A2A6400 RF A2A6400	RD A1C6400 RF A1C6400	RD A1C6400 RF A1C6400
6500 STATOR	Q R F B	RQ A2A6510 RR A2A6510 RF A2A6510 RB A2A6510	RQ A1B6510 RR A1B6510 RF A1B6510 RB A1B6510	RQ A2B6510 RR A2B6510 RF A2B6510 RB A2B6510	RQ A1C6510 RR A1C6510 RF A1C6510 RB A1C6510	RQ A2C6510 RR A2C6510 RF A2C6510 RB A2C6510
6800 SLINGER RING	CD/SS	RZ A2A6800	RZ A2A6800	RZ A2A6800	RZ A2A6800	RZ A2A6800
6800 SLINGER/PIN RETNR (2-PIECE OPTION)	CD/SS	423052800	423052800	423052800	423052800	423052800
6850 LANTERN RING	CD/SS	GR A2A6850	GR A2A6850	GR A2A6850	GR A2A6850	GR A2A6850
6900 PACKING	STD. PTFE	PC A2A6901 3403655001	PC A2A6901 3403655001	PC A2A6901 3403655001	PC A2A6901 3403655001	PC A2A6901 3403655001
7000 NAME PLATE	CD/SS	GA A2A7000	GA A2A7000	GA A2A7000	GA A2A7000	GA A2A7000
K O-RING	Q/R F/B	CA137 CF137	CA137 CF137	CA137 CF137	CA141 CF141	CA141 CF141
J SNAP RING	CD SS	EB007 EB507	EB007 EB507	EB007 EB507	EB015 EB015	EB015 EB015
R STATOR RING	CD/SS	EC022	EC028	EC028	EC034	EC034

*FRICTION DRIVEN SEAL, TYPE 43 OR EQUAL

**POSITIVE DRIVE SEAL, TYPE 680 OR EQUAL

NOTE: CONTACT FACTORY FOR REPLACEMENT MECHANICAL SEAL PART NUMBERS

PARTS LIST (Cont.)

REF. DESCRIPTION	TYPE	A4A PART NO.	A4B PART NO.	A4C PART NO.	A4D PART NO.	A4E PART NO.	A4F PART NO.
0100 BEARING HOUSING	CD/SS	CC A2A0110	CC A1D0110	CC A1D0110	CC A1F0110	CC A1F0110	CC A1H0110
0300 BEARING COVER	CD/SS		CC A1D0300	CC A1D0300	CC A1F0300	CC A1F0300	CC A1H0300
0500 GREASE RETAINER	CD/SS		MS A1D0500	MS A1D0500	MS A1F0500	MS A1F0500	MS A1H0500
0700 GREASE SEAL HSG.	CD/SS		MS A1D0700	MS A1D0700	MS A1F0700	MS A1F0700	MS A1H0700
0900 PACKING GLAND	CD/SS	SC A1A0910	SC A1D0910	SC A1D0910	SC A1F0910	SC A1F0910	SC A1H0910
1000 STUFFING BOX	CD SS	CC A2A1010 SC A2A1010	CC A1D1010 SC A1D1010	CC A1D1010 SC A1D1010	CC A1F1010 SC A1F1010	CC A1F1010 SC A1F1010	CC A1H1010 SC A1H1010
1000 SEAL HOUSING	* **	CD/SS CD/SS	SC A2A1011 4240833007	SC A1D1011 4240834007	SC A1D1011 4240834007	SC A1F1011 4240835007	SC A1F1011 4240835007
1100 SUCTION CHAMBER	CD SS	CC A1C1110 SC A1C1110	CC A1D1110 SC A1D1110	CC A1E1110 SC A1E1110	CC A1F1110 SC A1F1110	CC A1G1110 SC A1G1110	CC A1H1110 SC A1H1110
1200 STATOR GASKET	Q/R F B	GG A2A1200 GF A2A1200 GB A2A1200	GG A1B1200 GF A1B1200 GB A1B1200	GG A1C1200 GF A1C1200 GB A1C1200	GG A1D1200 GF A1D1200 GB A1D1200	GG A1E1200 GF A1E1200 GB A1E1200	GG A1F1200 GF A1F1200 GB A1F1200
1210 STATOR ADAPTOR GASKET	Q/R F B	GG A1C1200 GF A1C1200 GB A1C1200	GG A1D1200 GF A1D1200 GB A1D1200	GG A1E1200 GF A1E1200 GB A1E1200	GG A1F1200 GF A1F1200 GB A1F1200	GG A1G1200 GF A1G1200 GB A1G1200	GG A1H1200 GF A1H1200 GB A1H1200
1220 SUCTION CHAM. GASKET	Q/R F B	GG A2A1220 GF A2A1220 GB A2A1220	GG A1D1220 GF A1D1220 GB A1D1220	GG A1D1220 GF A1D1220 GB A1D1220	GG A1F1220 GF A1F1220 GB A1F1220	GG A1F1220 GF A1F1220 GB A1F1220	GG A1H1220 GF A1H1220 GB A1H1220
1240 INSP. PLATE GSKT.	Q/R F B					GG A1G1240 GF A1G1240 GB A1G1240	GG A1H1240 GF A1H1240 GB A1H1240
1400 DISCHARGE FLANGE	CD SS	MS A4A1410 SS A4A1410	MS A4B1410 SS A4B1410	MS A4C1410 SS A4C1410	MS A4D1410 SS A4D1410	MS A4E1410 SS A4E1410	MS A4F1410 SS A4F1410
1500 STATOR ADAPTOR	CD SS	MS A4A1510 SS A4A1510	MS A4B1510 SS A4B1510	MS A4C1510 SS A4C1510	MS A4D1510 SS A4D1510	MS A4E1510 SS A4E1510	MS A4F1510 SS A4F1510
1700 STATOR SUPPORT	CD/SS	MS A4A1710	CC A4B1710	CC A4C1710	CC A4D1710	CC A4E1710	CC A4F1710
1800 CLAMP RING	CD/SS CD/SS	MS A4A1810 MS A4A1811	MS A4B1810 MS A4B1811	MS A4C1810 MS A4C1811	MS A4D1810 MS A4D1811	MS A4E1810 MS A4E1811	MS A4F1810 MS A4F1811
1900 INSPECTION PLATE	CD SS					MS A1G1900 SS A1G1900	MS A1H1900 SS A1H1900
2000 SHAFT PIN	CD/SS	4220487017	4220488017	4220488017	4220489017	4220489017	4220492017
2100 INTERMEDIATE SHAFT	CD SS	4250393001 4250393017	4250394001 4250394017	4250395001 4250395017	4250396001 4250396017	4250397001 4250397017	4250398001 4250398017
2200 SEAL RING	Q/R F B	3207902206 3207905206 3207904206	3207902210 3207905210 3207904210	3207902210 3207905210 3207904210	3207902216 3207905216 3207904216	3207902216 3207905216 3207904216	3207902223 3207905223 3207904223
5000 ROTOR	CD SS	TS A4A5000 SS A4A5000	TS A4B5000 SS A4B5000	TS A4C5000 SS A4C5000	TS A4D5000 SS A4D5000	TS A4E5000 SS A4E5000	TS A4F5000 SS A4F5000
6000 DRIVE SHAFT	CD SS	AS A1C6000 SS A1C6000	AS A1D6000 SS A1D6000	AS A1E6000 SS A1E6000	AS A1F6000 SS A1F6000	AS A1G6000 SS A1G6000	AS A1H6000 SS A1H6000
6000 DRIVE SHAFT (2-PIECE OPTION)	CD SS	4250378001 4250378015	4250379001 4250379015	4250379001 4250379015	4250380001 4250380015	4250380001 4250380015	4250381001 4250381015
6100 RETAINING RING	CD/SS	ST A1C6100	ST A1D6100	ST A1E6100	ST A1F6100	ST A1G6100	ST A1H6100
6200 CONNECTING ROD	CD SS	AS A1C6200 AS A1C6200	AS A1D6200 AS A1D6200	AS A1E6200 AS A1E6200	AS A1F6200 AS A1F6200	AS A1G6200 AS A1G6200	AS A1H6200 AS A1H6200
6300 DRIVE PIN	CD/SS	TR A1C6300	TR A1D6300	TR A1E6300	TR A1F6300	TR A1G6300	TR A1H6300
6400 JOINT SEAL	Q/R F/R	RD A1C6400 RF A1C6400	RD A1D6400 RF A1D6400	RD A1E6400 RF A1E6400	RD A1F6400 RF A1F6400	RD A1G6400 RF A1G6400	RD A1H6400 RF A1H6400
6500 STATOR	Q R F B	RQ A4A6510 RR A4A6510 RF A4A6510 RB A4A6510	RQ A4B6510 RR A4B6510 RF A4B6510 RB A4B6510	RQ A4C6510 RR A4C6510 RF A4C6510 RB A4C6510	RQ A4D6510 RR A4D6510 RF A4D6510 RB A4D6510	RQ A4E6510 RR A4E6510 RF A4E6510 RB A4E6510	RQ A4F6510 RR A4F6510 RF A4F6510 RB A4F6510
6700 BEARING SHIMS	CD/SS		GP A1D6700	GP A1D6700	GP A1F6700	GP A1F6700	GP A1H6700
6800 SLINGER RING	CD/SS	RZ A2A6800	RZ A1D6800	RZ A1D6800	RZ A1F6800	RZ A1F6800	RZ A1H6800
6800 SLINGER/PIN RETNR (2-PIECE OPTION)	CD/SS	4230528000	4230529000	4230529000	4230530000	4230530000	4230531000
6850 LANTERN RING	CD/SS	GR A2A6850	GR A1D6850	GR A1D6850	GR A1F6850	GR A1F6850	GR A1H6850
6900 PACKING	STD. PTFE	PC A2A6901 3403655001	PC A1D6901 3403655002	PC A1D6901 3403655002	PC A1F6901 3403655003	PC A1F6901 3403655003	PC A1H6901 3403655004
7000 NAME PLATE	CD/SS	GA A2A7000	GA A2A7000	GA A2A7000	GA A1F7000	GA A1F7000	GA A1F7000
K O-RING	Q/R F/B	CA141 CF141	CA145 CF145	CA175 CF175	CA188 CF188	CA197 CF197	CA228 CF228
J SNAP RING	CD SS	EB015 EB515	EB020 EB520	EB027 EB527	EB036 EB536	EB045 EB545	EB049 EB549
R STATOR RING	CD/SS	EC022	EC028	EC034	EC039	EC046	EC055

*FRICTION DRIVE SEAL, TYPE 43 OR EQUAL
**POSITIVE DRIVE SEAL, TYPE 680 OR EQUAL

NOTE: CONTACT FACTORY FOR REPLACEMENT MECHANICAL SEAL PART NUMBERS

PARTS LIST (Cont.)

REF. DESCRIPTION	TYPE	A1D PART NO.	A2D PART NO.	A1E PART NO.	A2E PART NO.	A1F/A1FE PART NO.	A2F/A2FE PART NO.
0100 BEARING HOUSING	CD/SS	CC A1D0110	CC A1D0110	CC A1D0110	CC A1D0110	CC A1F0110	CC A1F0110
0300 BEARING COVER	CD/SS	CC A1D0300	CC A1D0300	CC A1D0300	CC A1D0300	CC A1F0300	CC A1F0300
0500 GREASE RETAINER	CD/SS	MS A1D0500	MS A1D0500	MS A1D0500	MS A1D0500	MS A1F0500	MS A1F0500
0700 GREASE SEAL HSG.	CD/SS	MS A1D0700	MS A1D0700	MS A1D0700	MS A1D0700	MS A1F0700	MS A1F0700
0900 PACKING GLAND	CD/SS	SC A1D0910	SC A1D0910	SC A1D0910	SC A1D0910	SC A1F0910	SC A1F0910
1000 STUFFING BOX	CD SS	CC A1D1010 SC A1D1010	CC A1D1010 SC A1D1010	CC A1D1010 SC A1D1010	CC A1D1010 SC A1D1010	CC A1F1010 SC A1F1010	CC A1F1010 SC A1F1010
1000 SEAL HOUSING	* ** CD/SS CD/SS	SC A1D1011 4240834007	SC A1D1011 4240834007	SC A1D1011 4240834007	SC A1D1011 4240834007	SC A1F1011 4240835007	SC A1F1011 4240835007
1100 SUCTION CHAMBER	CD SS	CC A1D1110 SC A1D1110	CC A1D1110 SC A1D1110	CC A1E1110 SC A1E1110	CC A1E1110 SC A1E1110	CC A1F1110 SC A1F1110	CC A1F1110 SC A1F1110
1200 STATOR GASKET	Q/R F B	GG A1D1200 GF A1D1200 GB A1D1200	GG A1D1200 GF A1D1200 GB A1D1200	GG A1E1200 GF A1E1200 GB A1E1200	GG A1E1200 GF A1E1200 GB A1E1200	GG A1F1200 GF A1F1200 GB A1F1200	GG A1F1200 GF A1F1200 GB A1F1200
1220 SUCTION CHAM. GASKET	Q/R F B	GG A1D1220 GF A1D1220 GB A1D1220	GG A1D1220 GF A1D1220 GB A1D1220	GG A1D1220 GF A1D1220 GB A1D1220	GG A1D1220 GF A1D1220 GB A1D1220	GG A1F1220 GF A1F1220 GB A1F1220	GG A1F1220 GF A1F1220 GB A1F1220
1240 INSP. PLATE GSKT.	Q/R F B			GG A1E1240 GF A1E1240 GB A1E1240	GG A1E1240 GF A1E1240 GB A1E1240	GG A1F1240 GF A1F1240 GB A1F1240	GG A1F1240 GF A1F1240 GB A1F1240
1400 DISCHARGE FLANGE	CD SS	MS A1D1410 SS A1D1410	MS A1D1410 SS A1D1410	MS A1E1410 SS A1E1410	MS A1E1410 SS A1E1410	MS A1F1410 SS A1F1410	MS A1F1410 SS A1F1410
1700 STATOR SUPPORT	CD/SS	CC A1D1710	CC A1D1710	CC A1E1710	CC A1E1710	CC A1F1710	CC A1F1710
1800 CLAMP RING	CD/SS	MS A1D1810	MS A1D1810	MS A1E1810	MS A1E1810	MS A1F1810	MS A1F1810
1900 INSPECTION PLATE	CD SS			MS A1E1900 SS A1E1900	MS A1E1900 SS A1E1900	MS A1F1900 SS A1F1900	MS A1F1900 SS A1F1900
2000 SHAFT PIN	CD/SS	4220488017	4220488017	4220488017	4220488017	4220489017	4220489017
2100 INTERMEDIATE SHAFT	CD SS	4250394001 4250394017	4250394001 4250394017	4250395001 4250395017	4250395001 4250395017	4250396001 4250396017	4250396001 4250396017
2200 SEAL O-RING	Q/R F B	3207902210 3207905210 3207904210	3207902210 3207905210 3207904210	3207902210 3207905210 327904210	3207902210 3207905210 3207904210	3207902216 3207905216 3207904216	3207902216 3207905216 3207904216
5000 ROTOR	CD CD SS SS	TS A1D5000 SS A1D5000	TS A2D5000 SS A2D5000	TS A1E5000 SS A1E5000	TS A2E5000 SS A2E5000	TS A1F5000 TS A1FE5000 SS A1F5000 SS A1FE5000	TS A2F5000 TS A2FE5000 SS A2F5000 SS A2FE5000
6000 DRIVE SHAFT	CD SS	AS A1D6000 SS A1D6000	AS A1D6000 SS A1D6000	AS A1E6000 SS A1E6000	AS A1E6000 SS A1E6000	AS A1F6000 SS A1F6000	AS A1F6000 SS A1F6000
6000 DRIVE SHAFT (2-PIECE OPTION)	CD SS	4250379001 4250379015	4250379001 4250379015	4250379001 4250379015	4250379001 4250379015	4250380001 4250380015	4250380001 4250380015
6100 RETAINING RING	CD/SS	ST A1D6100	ST A1D6100	ST A1E6100	ST A1E6100	ST A1F6100	ST A1F6100
6200 CONNECTING ROD	CD SS	AS A1D6200 AS A1D6200	AS A1D6200 AS A1D6200	AS A1E6200 AS A1E6200	AS A1E6200 AS A1E6200	AS A1F6200 AS A1F6200	AS A1F6200 AS A1F6200
6300 DRIVE PIN	CD/SS	TR A1D6300	TR A1D6300	TR A1E6300	TR A1E6300	TR A1F6300	TR A1F6300
6400 JOINT SEAL	Q/R F/B	RD A1D6400 RF A1D6400	RD A1D6400 RF A1D6400	RD A1E6400 RF A1E6400	RD A1E6400 RF A1E6400	RD A1F6400 RF A1F6400	RD A1F6400 RF A1F6400
6500 STATOR	Q Q R R R F B B	RQ A1D6510 RR A1D6510 RF A1D6510 RB A1D6510	RQ A2D6510 RR A2D6510 RF A2D6510 RB A2D6510	RQ A1E6510 RR A1E6510 RF A1E6510 RB A1E6510	RQ A2E6510 RR A2E6510 RF A2E6510 RB A2E6510	RQ A1F6510 RQ A1FE6510 RR A1F6510 RR A1FE6510 RF A1F6510 RF A1FE6510 RB A1F6510 RB A1FE6510	RQ A2F6510 RQ A2FE6510 RR A2F6510 RR A2FE6510 RF A2F6510 RF A2FE6510 RB A2F6510 RB A2FE6510
6700 BEARING SHIMS	CD/SS	GP A1D6700	GP A1D6700	GP A1D6700	GP A1D6700	GP A1F6700	GP A1F6700
6800 SLINGER RING	CD/SS	RZ A1D6800	RZ A1D6800	RZ A1D6800	RZ A1D6800	RZ A1F6800	RZ A1F6800
6800 SLINGER/PIN RETNR (2-PIECE OPTION)	CD/SS	4230529000	4230529000	4230529000	4230529000	4230530000	4230530000
6850 LANTERN RING	CD/SS	GR A1D6850	GR A1D6850	GR A1D6850	GR A1D6850	GR A1F6850	GR A1F6850
6900 PACKING	STD. PTFE	PC A1D6901 3403655002	PC A1D6901 3403655002	PC A1D6901 3403655002	PC A1D6901 3403655002	PC A1F6901 3403655003	PC A1F6901 3403655003
7000 NAME PLATE	CD/SS	GA A2A7000	GA A2A7000	GA A2A7000	GA A2A7000	GA A1F7000	GA A1F7000
K O-RING	Q/R F/B	CA145 CF145	CA145 CF145	CA175 CF175	CA175 CF175	CA188 CF188	CA188 CF188
J SNAP RING	CD SS	EB020 EB520	EB020 EB520	EB027 EB527	EB027 EB527	EB036 EB536	EB036 EB536
R STATOR RING	CD/SS	EC039	EC039	EC046	EC046	EC055	EC055

*FRICTION DRIVE SEAL, TYPE 43 OR EQUAL

**POSITIVE DRIVE SEAL, TYPE 680 OR EQUAL

NOTE: CONTACT FACTORY FOR REPLACEMENT MECHANICAL SEAL PART NUMBERS

PARTS LIST (Cont.)

REF. DESCRIPTION	TYPE	A1G A1GE PART NO.	A2G A2GE PART NO.	A1H A1HE PART NO.	A2H A2HE PART NO.	A1J A1JE PART NO.	A2J A2JE PART NO.	A1K A1KE PART NO.
0100 BEARING HOUSING	CD/SS	CC A1F0110	CC A1F0110	CC A1H0110	CC A1H0110	CC A1H0110	CC A1H0110	CC A1H0110
0300 BEARING COVER	CD/SS	CC A1F0300	CC A1F0300	CC A1H0300	CC A1H0300	CC A1H0300	CC A1H0300	CC A1H0300
0500 GREASE RETAINER	CD/SS	MS A1F0500	MS A1F0500	MS A1H0500	MS A1H0500	MS A1H0500	MS A1H0500	MS A1H0500
0700 GREASE SEAL HSG.	CD/SS	MS A1F0700	MS A1F0700	MS A1H0700	MS A1H0700	MS A1H0700	MS A1H0700	MS A1H0700
0900 PACKING GLAND	CD/SS	SC A1F0910	SC A1F0910	SC A1H0910	SC A1H0910	SC A1H0910	SC A1H0910	SC A1H0910
1000 STUFFING BOX	CD SS	CC A1F1010 SC A1F1010	CC A1F1010 SC A1F1010	CC A1H1010 SC A1H1010	CC A1H1010 SC A1H1010	CC A1H1010 SC A1H1010	CC A1H1010 SC A1H1010	CC A1H1010 SC A1H1010
1000 SEAL HOUSING	CD/SS CD/SS	SC A1F1011 4240835007	SC A1F1011 4240835007	SC A1H1011 4240836007	SC A1H1011 4240836007	SC A1H1011 4240836007	SC A1H1011 4240836007	SC A1H1011 4240836007
1100 SUCTION CHAMBER	CD SS	CC A1G1110 SC A1G1110	CC A1G1110 SC A1G1110	CC A1H1110 SC A1H1110	CC A1H1110 SC A1H1110	CC A1H1110 SC A1H1110	CC A1H1110 SC A1H1110	CC A1H1110 SC A1H1110
1200 STATOR GASKET	Q/R F B	GG A1G1200 GF A1G1200 GB A1G1200	GG A1G1200 GF A1G1200 GB A1G1200	GG A1H1200 GF A1H1200 GB A1H1200	GG A1H1200 GF A1H1200 GB A1H1200	GG A1H1200 GF A1H1200 GB A1H1200	GG A1H1200 GF A1H1200 GB A1H1200	GG A1H1200 GF A1H1200 GB A1H1200
1220 SUCTION CHAM. GASKET	Q/R F B	GG A1F1220 GF A1F1220 GB A1F1220	GG A1F1220 GF A1F1220 GB A1F1220	GG A1H1220 GF A1H1220 GB A1H1220	GG A1H1220 GF A1H1220 GB A1H1220	GG A1H1220 GF A1H1220 GB A1H1220	GG A1H1220 GF A1H1220 GB A1H1220	GG A1H1220 GF A1H1220 GB A1H1220
1240 INSP. PLATE GSKT.	Q/R F B	GG A1G1240 GF A1G1240 GB A1G1240	GG A1G1240 GF A1G1240 GB A1G1240	GG A1H1240 GF A1H1240 GB A1H1240	GG A1H1240 GF A1H1240 GB A1H1240	GG A1H1240 GF A1H1240 GB A1H1240	GG A1H1240 GF A1H1240 GB A1H1240	GG A1H1240 GF A1H1240 GB A1H1240
1400 DISCHARGE FLANGE	CD SS	MS A1G1410 SS A1G1410	MS A1G1410 SS A1G1410	MS A1H1410 SS A1H1410	MS A1H1410 SS A1H1410	MS A1H1410 SS A1H1410	MS A1H1410 SS A1H1410	MS A1H1410 SS A1H1410
1700 STATOR SUPPORT	CD/SS	CC A1G1710	CC A1G1710	CC A1H1710	CC A1H1710	CC A1H1710	CC A1H1710	CC A1H1710
1800 CLAMP RING	CD/SS	MS A1G1810	MS A1G1810	MS A1H1810	MS A1H1810	MS A1H1810	MS A1H1810	MS A1H1810
1900 INSPECTION PLATE	CD SS	MS A1G1900 SS A1G1900	MS A1G1900 SS A1G1900	MS A1H1900 SS A1H1900	MS A1H1900 SS A1H1900	MS A1H1900 SS A1H1900	MS A1H1900 SS A1H1900	MS A1H1900 SS A1H1900
2000 SHAFT PIN	CD/SS	4220489017	4220489017	4220492017	4220492017	4220492017	4220492017	4220492017
2100 INTERMEDIATE SHAFT	CD SS	4250397001 425397017	4250397001 4250397017	4250398001 4250398017	4250398001 4250398017	4250398001 4250398017	4250398001 4250398017	4250398001 4250398017
2200 SEAL O-RING	Q/R F B	3207902216 3207905216 3207904216	3207902216 3207905216 3207904216	3207902223 3207905223 3207904223	3207902223 3207905223 3207904223	3207902223 3207905223 3207904223	3207902223 3207905223 3207904223	3207902223 3207905223 3207904223
5000 ROTOR	CD CD SS SS SS	TS A1G5000 TS A1GE5000 SS A1G5000 SS A1GE5000	TS A2G5000 TS A2GE5000 SS A2G5000 SS A2GE5000	TS A1H5000 TS A1HE5000 SS A1H5000 SS A1HE5000	TS A2H5000 TS A2HE5000 SS A2H5000 SS A2HE5000	TS A1J5000 TS A1JE5000 SS A1J5000 SS A1JE5000	TS A2J5000 TS A2JE5000 SS A2J5000 SS A2JE5000	TS A1K5000 TS A1KE5000 SS A1K5000 SS A1KE5000
6000 DRIVE SHAFT	CD SS	AS A1G6000 SS A1G6000	AS A1G6000 SS A1G6000	AS A1H6000 SS A1H6000	AS A1H6000 SS A1H6000	AS A1H6000 SS A1H6000	AS A1H6000 SS A1H6000	AS A1H6000 SS A1H6000
6000 DRIVE SHAFT (2-PIECE OPTION)	CD SS	4250380001 4250380015	4250380001 4250380015	4250381001 4250381001	4250381001 4250381001	4250381001 4250381001	4250381001 4250381001	4250381001 4250381001
6100 RETAINING RING	CD/SS	ST A1G6100	ST A1G6100	ST A1H6100	ST A1H6100	ST A1H6100	ST A1H6100	ST A1H6100
6200 CONNECTING ROD	CD SS	AS A1G6200 AS A1G6200	AS A1G6200 AS A1G6200	AS A1H6200 AS A1H6200	AS A1H6200 AS A1H6200	AS A1H6200 AS A1H6200	AS A1H6200 AS A1H6200	AS A1H6200 AS A1H6200
6300 DRIVE PIN	CD/SS	TR A1G6300	TR A1G6300	TR A1H6300	TR A1H6300	TR A1H6300	TR A1H6300	TR A1H6300
6400 JOINT SEAL	Q/R F/B	RD A1G6400 RF A1G6400	RD A1G6400 RF A1G6400	RD A1H6400 RF A1H6400	RD A1H6400 RF A1H6400	RD A1H6400 RF A1H6400	RD A1H6400 RF A1H6400	RD A1H6400 RF A1H6400
6500 STATOR	Q Q R R R F B B	RQ A1G6510 RQ A1GE6510 RR A1G6510 RR A1GE6510 RF A1G6510 RB A1G6510 RB A1GE6510	RQ A2G6510 RQ A2GE6510 RR A2G6510 RR A2GE6510 RF A2G6510 RB A2G6510 RB A2GE6510	RQ A1H6510 RQ A1HE6510 RR A1H6510 RR A1HE6510 RF A1H6510 RB A1H6510 RB A1HE6510	RQ A2H6510 RQ A2HE6510 RR A2H6510 RR A2HE6510 RF A2H6510 RB A2H6510 RB A2HE6510	RQ A1J6510 RQ A1JE6510 RR A1J6510 RR A1JE6510 RF A1J6510 RB A1J6510 RB A1JE6510	RQ A2J6510 RQ A2JE6510 RR A2J6510 RR A2JE6510 RF A2J6510 RB A2J6510 RB A2JE6510	RQ A1K6510 RQ A1KE6510 RR A1K6510 RR A1KE6510 RF A1K6510 RB A1K6510 RB A1KE6510
6700 BEARING SHIMS	CD/SS	GP A1F6700	GP A1F6700	GP A1H6700	GP A1H6700	GP A1H6700	GP A1H6700	GP A1H6700
6800 SLINGER RING	CD/SS	RZ A1F6800	RZ A1F6800	RZ A1H6800	RZ A1H6800	RZ A1H6800	RZ A1H6800	RZ A1H6800
6800 SLINGER/PIN RETNR (2-PIECE OPTION)	CD/SS	4230530000	4230530000	4230531000	4230531000	4230531000	4230531000	4230531000
6850 LANTERN RING	CD/SS	GR A1F6850	GR A1F6850	GR A1H6850	GR A1H6850	GR A1H6850	GR A1H6850	GR A1H6850
6900 PACKING	STD. PTFE	PC A1F6901 3403655003	PC A1F6901 3403655003	PC A1H6901 3403655004	PC A1H6901 3403655004	PC A1H6901 3403655004	PC A1H6901 3403655004	PC A1H6901 3403655004
7000 NAME PLATE	CD/SS	GA A1F7000	GA A1F7000	GA A1H7000	GA A1H7000	GA A1H7000	GA A1H7000	GA A1H7000
K O-RING	Q/R F/B	CA197 CF197	CA197 CF197	CA228 CF228	CA228 CF228	CA228 CF228	CA228 CF228	CA228 CF228
J SNAP RING	CD SS	EB045 EB545	EB045 EB545	EB049 EB549	EB049 EB549	EB049 EB549	EB049 EB549	EB049 EB549
R STATOR RING	CD/SS	EC060	EC060	EC065	EC065	EC065	EC065	EC065

*FRICTION DRIVE SEAL, TYPE 43 OR EQUAL

**POSITIVE DRIVE SEAL, TYPE 680 OR EQUAL

NOTE: CONTACT FACTORY FOR REPLACEMENT MECHANICAL SEAL PART NUMBERS

PARTS LIST (Cont.)

REF. DESCRIPTION	TYPE	B2A PART NO.	B4A PART NO.	B1B PART NO.	B2B PART NO.	B4B PART NO.	B1C PART NO.
0100 DRIVE ADAPTOR	CD/SS	CC B2A0100	CC B2A0100	CC B2A0100	CC B2A0100	CC B1D0100	CC B2A0100
0900 PACKING GLAND	CD/SS	SC A2A0910	SC A2A0910	SC A2A0910	SC A2A0910	SC A1D0910	SC A2A0910
1000 STUFFING BOX	CD SS	CC A2A1010 SC A2A1010	CC A2A1010 SC A2A1010	CC A2A1010 SC A2A1010	CC A2A1010 SC A2A1010	CC A1D1010 SC A1D1010	CC A2A1010 SC A2A1010
1000 SEAL HOUSING	* ** CD/SS	SC A2A1011 4240833007	SC A2A1011 4240833007	SC A2A1011 4240833007	SC A2A1011 4240833007	SC A2A1011 4240833007	SC A2A1011 4240833007
1100 SUCTION CHAMBER	CD SS	CC A2A1110 SC A2A1110	CC A1C1110 SC A1C1110	CC A1B1110 SC A1B1110	CC A1B1110 SC A1B1110	CC A1D1110 SC A1D1110	CC A1C1110 SC A1C1110
1200 STATOR GASKET	Q/R F B	GG A2A1200 GF A2A1200 GB A2A1200	GG A2A1200 GF A2A1200 GB A2A1200	GG A1B1200 GF A1B1200 GB A1B1200	GG A1B1200 GF A1B1200 GB A1B1200	GG A1B1200 GF A1B1200 GB A1B1200	GG A1C1200 GF A1C1200 GB A1C1200
1210 STATOR ADAPTOR GASKET	Q/R F B		GG A1C1200 GF A1C1200 GB A1C1200			GG A1D1200 GF A1D1200 GB A1D1200	
1220 SUCTION CHAM. GASKET	Q/R F B	GG A2A1220 GF A2A1220 GB A2A1220	GG A2A1220 GF A2A1220 GB A2A1220	GG A2A1220 GF A2A1220 GB A2A1220	GG A2A1220 GF A2A1220 GB A2A1220	GG A1D1220 GF A1D1220 GB A1D1220	GG A2A1220 GF A2A1220 GB A2A1220
1400 DISCHARGE FLANGE	CD SS	MS A2A1410 SS A2A1410	MS A4A1410 SS A4A1410	MS A1B1410 SS A1B1410	MS A1B1410 SS A1B1410	MS A4B1410 SS A4B1410	MS A1C1410 SS A1C1410
1500 STATOR ADAPTOR	CD SS		MS A4A1510 SS A4A1510			MS A4B1510 SS A4B1510	
1600 LOCKING RING	CD/SS	MT B2A1600	MT B2A1600	MT B2A1600	MT B2A1600	MT B1D1600	MT B2A1600
1700 STATOR SUPPORT	CD/SS	MS A2A1710	MS A4A1710	MS A2A1710	MS A2A1710	CCA4B1710	MD A1C1710
1800 CLAMP RING	CD/SS CD/SS	MS A2A1810	MS A4A1810 MS A4A1811	MS A1B1810	MS A1B1810	MS A4B1810 MS A4B1811	MS A1C1810
2000 SHAFT PIN	CD/SS	4220487017	4220487017	4220487017	4220487017	4220488017	4220487017
5000 ROTOR	CD SS	TS A2A5000 SS A2A5000	TS A4A5000 SS A4A5000	TS A1B5000 SS A1B5000	TS A2B5000 SS A2B5000	TS A4B5000 SS A4B5000	TS A1C5000 SS A1C5000
6000 DRIVE SHAFT - KEY	CD SS	AS B2A6000 SS B2A6000	AS B1C6000 SS B1C6000	AS B2A6000 SS B2A6000	AS B2A6000 SS B2A6000	AS B1D6000 SS B1D6000	AS B1C6000 SS B1C6000
6000 CC DRIVE SHAFT - PIN	CD SS	4250778001 4250778015	4250779001 4250779015	4250778001 4250778015	4250778001 4250778015	4250780001 4250780015	4250779001 4250779015
6100 RETAINING RING	CD/SS	ST A2A6100	ST A1C6100	ST A2A6100	ST A2A6100	ST A1D6100	ST A1C6100
6200 CONNECTING ROD	CD SS	AS A2A6200 AS A2A6200	AS A1C6200 AS A1C6200	AS A2A6200 AS A2A6200	AS A2A6200 AS A2A6200	AS A1D6200 AS A1D6200	AS A1C6200 AS A1C6200
6300 DRIVE PIN	CD/SS	TR A2A6300	TR A1C6300	TR A2A6300	TR A2A6300	TR A1D6300	TR A1C6300
6400 JOINT SEAL	Q/R F/B	RD A2A6400 RF A2A6400	RD A1C6400 RF A1C6400	RD A2A6400 RF A2A6400	RD A2A6400 RF A2A6400	RD A1D6400 RF A1D6400	RD A1C6400 RF A1C6400
6500 STATOR	Q R F B	RQ A2A6510 RR A2A6510 RF A2A6510 RB A2A6510	RQ A4A6510 RR A4A6510 RF A4A6510 RB A4A6510	RQ A1B6510 RR A1B6510 RF A1B6510 RB A1B6510	RQ A2B6510 RR A2B6510 RF A2B6510 RB A2B6510	RQ A4B6510 RR A4B6510 RF A4B6510 RB A4B6510	RQ A1C6510 RR A1C6510 RF A1C6510 RB A1C6510
6800 SLINGER RING - KEY	CD/SS	RZ A2A6800	RZ A2A6800	RZ A2A6800	RZ A2A6800	RZ A1D6800	RZ A2A6800
6800 SLINGER/PIN RETNR - 2 PC/CC	CD/SS	4230528000	4230528000	4230528000	4230528000	4230529000	4230528000
6850 LANTERN RING	CD/SS	GR A2A6850	GR A2A6850	GR A2A6850	GR A2A6850	GR A1D6850	GR A2A6850
6900 PACKING	STD. PTFE	PC A2A6901 3403655001	PC A2A6901 3403655001	PC A2A6901 3403655001	PC A2A6901 3403655001	PC A1D6901 3403655002	PC A2A6901 3403655001
7000 NAME PLATE	CD/SS	GA B2A7000	GA B2A7000	GA B2A7000	GA B2A7000	GA B2A7000	GA B2A7000
K O-RING	Q/R F/B	CA137 CF137	CA141 CF141	CA137 CF137	CA137 CF137	CA145 CF145	CA141 CF141
J SNAP RING	CD SS	EB007 EB507	EB015 EB515	EB007 EB507	EB007 EB507	EB020 EB520	EB015 EB515
R STATOR RING	CD/SS	EC022	EC022	EC028	EC028	EC028	EC034

*FRICTION DRIVE SEAL, TYPE 43 OR EQUAL

**POSITIVE DRIVE SEAL, TYPE 680 OR EQUAL

NOTE: CONTACT FACTORY FOR REPLACEMENT MECHANICAL SEAL PART NUMBERS

PARTS LIST (Cont.)

REF. DESCRIPTION	TYPE	B2C PART NO.	B4C PART NO.	B1D PART NO.	B2D PART NO.	B4D PART NO.	B1E PART NO.
0100 DRIVE ADAPTOR	CD/SS	CC B2A0100	CC B1D0100	CC B1D0100	CC B1D0100	CC B1F0100	CC B1D0100
0900 PACKING GLAND	CD/SS	SC A2A0910	SC A1D0910	SC A1D0910	SC A1D0910	SC A1F0910	SC A1D0910
1000 STUFFING BOX	CD SS	CC A2A1010 SC A2A1010	CC A1D1010 SC A1D1010	CC A1D1010 SC A1D1010	CC A1D1010 SC A1D1010	CC A1F1010 SC A1F1010	CC A1D1010 SC A1D1010
1000 SEAL HOUSING	CD/SS CD/SS	SC A2A1011 4240833007	SC A1D1011 4240834007	SC A1D1011 4240834007	SC A1D1011 4240834007	SC A1F1011 4240835007	SC A1D1011 4240834007
1100 SUCTION CHAMBER	CD SS	CC A1C1110 SC A1C1110	CC A1E1110 SC A1E1000	CC A1D1110 SC A1D1110	CC A1D1110 SC A1D1110	CC A1F1110 SC A1F1110	CC A1E1110 SC A1E1110
1200 STATOR GASKET	Q/R F B	GG A1C1200 GF A1C1200 GB A1C1200	GG A1C1200 GF A1C1200 GB A1C1200	GG A1D1200 GF A1D1200 GB A1D1200	GG A1D1200 GF A1D1200 GB A1D1200	GG A1D1200 GF A1D1200 GB A1D1200	GG A1E1200 GF A1E1200 GB A1E1200
1210 STATOR ADAPTOR GASKET	Q/R F B		GG A1E1200 GF A1E1200 GB A1E1200			GG A1F1200 GF A1F1200 GB A1F1200	
1220 SUCTION CHAM. GASKET	Q/R F B	GG A2A1220 GF A2A1220 GB A2A1220	GG A1D1220 GF A1D1220 GB A1D1220	GG A1D1220 GF A1D1220 GB A1D1220	GG A1D1220 GF A1D1220 GB A1D1220	GG A1F1220 GF A1F1220 GB A1F1220	GG A1D1220 GF A1D1220 GB A1D1220
1240 INSPT. PLATE GSKT.	Q/R F B						GG A1E1240 GF A1E1240 GB A1E1240
1400 DISCHARGE FLANGE	CD SS	MS A1C1410 SS A1C1410	MS A4C1410 SS A4C1410	MS A1D1410 SS A1D1410	MS A1D1410 SS A1D1410	MS A1D1410 SS A1D1410	MS A1E1410 SS A1E1410
1500 STATOR ADAPTOR	CD SS		MS A4C1510 SS A4C1510			MS A4D1510 SS A4D1510	
1600 LOCKING RING	CD/SS	MT B2A1600	MT B1D1600	MT B1D1600	MT B1D1600	MT B1F1600	MT B1D1600
1700 STATOR SUPPORT	CD/SS	MS A1C1710	MS A4C1710	MS A1D1710	CC A1D1710	CC A4D1710	CC A1E1710
1800 CLAMP RING	CD/SS CD/SS	MS A1C1810	MS A4C1810 MS A4C1811	MS A1D1810	MS A1D1810	MS A4D1810 MS A4D1811	MS A1E1810
1900 INSPECTION PLATE	CD SS						MS A1E1900 SS A1E1900
2000 SHAFT PIN	CD/SS	4220487017	4220488017	4220488017	4220488017	4220489017	4220488017
5000 ROTOR	CD SS	TS A2C5000 SS A2C5000	TS A4C5000 SS A4C5000	TS A1D5000 SS A1D5000	TS A2D5000 SS A2D5000	TS A4D5000 SS A4D5000	TS A1E5000 SS A1E5000
6000 CC DRIVE SHAFT - KEY	CD SS	AS B1C6000 SS B1C6000	AS B1E6000 SS B1E6000	AS B1D6000 SS B1D6000	AS B1D6000 SS B1D6000	AS B1F6000 SS B1F6000	AS B1E6000 SS B1E6000
6000 CC DRIVE SHAFT - PIN	CD SS	4250779001 4250779015	4250760001 4250760015	4250780001 4250780015	4250780001 4250780015	4250745001 4250745015	4250760001 4250760015
6100 RETAINING RING	CD/SS	ST A1C6100	ST A1E6100	ST A1D6100	ST A1D6100	ST A1F6100	ST A1E6100
6200 CONNECTING ROD	CD SS	AS A1C6200 AS A1C6200	AS A1E6200 SS A1E6200	AS A1D6200 AS A1D6200	AS A1D6200 AS A1D6200	AS A1F6200 SS A1F6200	AS A1E6200 SS A1E6200
6300 DRIVE PIN	CD/SS	TR A1C6300	TR A1E6300	TR A1D6300	TR A1D6300	TR A1F6300	TR A1E6300
6400 JOINT SEAL	Q/R F/B	RD A1C6400 RF A1C6400	RD A1E6400 RF A1E6400	RD A1D6400 RF A1D6400	RD A1D6400 RF A1D6400	RD A1F6400 RF A1F6400	RD A1E6400 RF A1E6400
6500 STATOR	Q R F B	RQ A2C6510 RR A2C6510 RF A2C6510 RB A2C6510	RQ A4C6510 RR A4C6510 RF A4C6510 RB A4C6510	RQ A1D6510 RR A1D6510 RF A1D6510 RB A1D6510	RQ A2D6510 RR A2D6510 RF A2D6510 RB A2D6510	RQ A4D6510 RR A4D6510 RF A4D6510 RB A4D6510	RQ A1E6510 RR A1E6510 RF A1E6510 RB A1E6510
6800 SLINGER RING - KEY	CD/SS	RZ A2A6800	RZ A1D6800	RZ A1D6800	RZ A1D6800	RZ A1F6800	RZ A1D6800
6800 SLINGER/PIN RETNR - 2 PC/CC	CD/SS	4230528000	4230529000	4230529000	4230529000	4230530000	4230529000
6850 LANTERN RING	CD/SS	GR A2A6850	GR A1D6850	GR A1D6850	GR A1D6850	GR A1F6850	GR A1D6850
6900 PACKING	STD. PTFE	PC A2A6901 3403655001	PC A1D6901 3403655002	PC A1D6901 3403655002	PC A1D6901 3403655002	PC A1F6901 3403655003	PC A1F6901 3403655002
7000 NAME PLATE	CD/SS	GA B2A7000	GA B2A7000	GA B2A7000	GA B2A7000	GA B2A7000	GA B2A7000
K O-RING	Q/R F/B	CA141 CF141	CA175 CF175	CA145 CF145	CA145 CF145	CA188 CF188	CA175 CF175
J SNAP RING	CD SS	EB015 EB515	EB027 EB527	EB020 EB520	EB020 EB520	EB036 EB536	EB027 EB527
R STATOR RING	CD/SS	EC034	EC034	EC039	EC039	EC039	EC046

*FRICTION DRIVE SEAL, TYPE 43 OR EQUAL

**POSITIVE DRIVE SEAL, TYPE 680 OR EQUAL

NOTE: CONTACT FACTORY FOR REPLACEMENT MECHANICAL SEAL PART NUMBERS

PARTS LIST (Cont.)

REF. DESCRIPTION	TYPE	B2E PART NO.	B4E PART NO.	B1F/B1FE PART NO.	B2F/B2FE PART NO.	B4F PART NO.	B1G/B1GE PART NO.
0100 DRIVE ADAPTOR	CD/SS	CC B1D0100	CC B1F0100	CC B1F0100	CC B1F0100	CC B1H0100	CC B1F0100
0900 PACKING GLAND	CD/SS	SC A1D0910	SC A1F0910	SC A1F0910	SC A1F0910	SC A1H0910	SC A1F0910
1000 STUFFING BOX	CD SS	CC A1D1010 SC A1D1010	CC A1F1010 SC A1F1010	CC A1F1010 SC A1F1010	CC A1F1010 SC A1F1010	CC A1H1010 SC A1H1010	CC A1F1010 SC A1F1010
1000 SEAL HOUSING	* ** CD/SS	SC A1D1011 4240834007	SC A1F1011 4240835007	SC A1F1011 4240835007	SC A1F1011 4240835007	SC A1H1011 4240836007	SC A1F1011 4240835007
1100 SUCTION CHAMBER	CD SS	CC A1E1110 SC A1E1110	CC A1G1110 SC A1G1110	CC A1F1110 SC A1F1110	CC A1F1110 SC A1F1110	CC A1H1110 SC A1H1110	CC A1G1110 SC A1G1110
1200 STATOR GASKET	Q/R F B	GG A1E1200 GF A1E1200 GB A1E1200	GG A1E1200 GF A1E1200 GB A1E1200	GG A1F1200 GF A1F1200 GB A1F1200	GG A1F1200 GF A1F1200 GB A1F1200	GG A1F1200 GF A1F1200 GB A1F1200	GG A1G1200 GF A1G1200 GB A1G1200
1210 STATOR ADAPTOR GASKET	Q/R F B		GG A1G1200 GF A1G1200 GB A1G1200			GG A1H1200 GF A1H1200 GB A1H1200	
1220 SUCTION CHAM. GASKET	Q/R F B	GG A1D1220 GF A1D1220 GB A1D1220	GG A1F1220 GF A1F1220 GB A1F1220	GG A1F1220 GF A1F1220 GB A1F1220	GG A1F1220 GF A1F1220 GB A1F1220	GG A1H1220 GF A1H1220 GB A1H1220	GG A1F1220 GF A1F1220 GB A1F1220
1240 INSPT. PLATE GSKT.	Q/R F BA	GG A1E1240 GF A1E1240 GB A1E1240	GG A1G1240 GF A1G1240 GB A1G1240	GG A1F1240 GF A1F1240 GB A1F1240	GG A1F1240 GF A1F1240 GB A1F1240	GG A1H1240 GF A1H1240 GB A1H1240	GG A1G1240 GF A1G1240 GB A1G1240
1400 DISCHARGE FLANGE	CD SS	MS A1E1410 SS A1E1410	MS A4E1410 SS A4E1410	MS A1F1410 SS A1F1410	MS A1F1410 SS A1F1410	MS A4F1410 SS A4F1410	MS A1G1410 SS A1G1410
1500 STATOR ADAPTOR	CD SS		MS A4E1510 SS A4E1510			MS A4F1510 SS A4F1510	
1600 LOCKING RING	CD/SS	MT B1D1600	MT B1F1600	MT B1F1600	MT B1F1600		MT B1F1600
1700 STATOR SUPPORT	CD/SS	CC A1E1710	CC A1E1710	CC A1F1710	CC A1F1710	CC A4F1710	CC A1G1710
1800 CLAMP RING	CD/SS CD/SS	MS A1E1810	MS A4E1810 MS A4E1811	MS A1F1810	MS A1F1810	MS A4F1810 MS A4F1811	MS A1G1810
1900 INSPECTION PLATE	CD SS	MS A1E1900 SS A1E1900	MS A1G1900 SS A1G1900	MS A1F1900 SS A1F1900	MS A1F1900 SS A1F1900	MS A1H1900 SS A1H1900	MS A1G1900 SS A1G1900
2000 SHAFT PIN	CD/SS	4220488017	4220489017	4220489017	4220489017	4220492017	4220489017
5000 ROTOR	CD CD SS SS	TS A2E5000 SS A2E5000	TS A4E5000 SS A4E5000	TS A1F5000 TS A1FE5000 SS A1F5000 SS A1FE5000	TS A2F5000 TS A2FE5000 SS A2F5000 SS A2FE5000	TS A4F5000 SS A4F5000	TS A1G5000 TS A1GE5000 SS A1G5000 SS A1GE5000
6000 DRIVE SHAFT - KEY	CD SS	AS B1E6000 SS B1E6000	AS B1G6000 SS B1G6000	AS B1F6000 SS B1F6000	AS B1F6000 SS B1F6000		AS B1G6000 SS B1G6000
6000 CC DRIVE SHAFT - PIN	CD SS	4250760001 4250760015	4250744001 4250744015	4250745001 4250745015	4250745001 4250745015	AS B1H6000 SS B1H6000	4250744001 4250744015
6100 RETAINING RING	CD/SS	ST A1E6100	ST A1G6100	ST A1F6100	ST A1F6100	ST A1H6100	ST A1G6100
6200 CONNECTING ROD	CD SS	AS A1E6200 SS A1E6200	AS A1G6200 SS A1G6200	AS A1F6200 SS A1F6200	AS A1F6200 SS A1F6200	AS A1H6200 SS A1H6200	AS A1G6200 SS A1G6200
6300 DRIVE PIN	CD/SS	TR A1E6300	TR A1G6300	TR A1F6300	TR A1F6300	TR A1H6300	TR A1G6300
6400 JOINT SEAL	Q/R F/B	RD A1E6400 RF A1E6400	RD A1G6400 RF A1G6400	RD A1F6400 RF A1F6400	RD A1F6400 RF A1F6400	RD A1H6400 RF A1H6400	RD A1G6400 RF A1G6400
6500 STATOR	Q Q R R F B B	RQ A2E6510 RR A2E6510 RF A2E6510 RB A2E6510	RQ A4E6510 RR A4E6510 RF A4E6510 RB A4E6510	RQ A1F6510 RQ A1FE6510 RR A1F6510 RR A1FE6510 RF A1F6510 RB A1F6510 RB A1FE6510	RQ A2F6510 RQ A2FE6510 RR A2F6510 RR A2FE6510 RF A2F6510 RB A2F6510 RB A2FE6510	RQ A4F6510 RR A4F6510 RF A4F6510 RB A4F6510	RQ A1G6510 RQ A1GE6510 RR A1G6510 RR A1GE6510 RF A1G6510 RB A1G6510 RB A1GE6510
6800 SLINGER RING - KEY	CD/SS	RZ A1D6800	RZ A1F6800	RZ A1F6800	RZ A1F6800		RZ A1F6800
6800 SLINGER/PIN RETNR - 2 PC/CC	CD/SS	4230529000	4230530000	4230530000	4230530000	4230531000	4230530000
6850 LANTERN RING	CD/SS	GR A1D6850	GR A1F6850	GR A1F6850	GR A1F6850	GR A1H6850	GR A1F6850
6900 PACKING	STD. PTFE	PC A1D6901 3403655002	PC A1F6901 3403655003	PC A1F6901 3403655003	PC A1F6901 3403655003	PC A1H6901 3403655004	PC A1F6901 3403655003
7000 NAME PLATE	CD/SS	GA B2A7000	GA B2A7000	GA B2A7000	GA B2A7000	GA B2A7000	GA B2A7000
K O-RING	Q/R F/B	CA175 CF175	CA197 CF197	CA188 CF188	CA188 CF188	CA228 CF228	CA197 CF197
J SNAP RING	CD SS	EB027 EB527	EB045 EB545	EB036 EB536	EB036 EB536	EB049 EB549	EB045 EB545
R STATOR RING	CD/SS	EC046	EC046	EC055	EC055	EC065	EC060

*FRICTION DRIVE SEAL, TYPE 43 OR EQUAL

**POSITIVE DRIVE SEAL, TYPE 680 OR EQUAL

NOTE: CONTACT FACTORY FOR REPLACEMENT MECHANICAL SEAL PART NUMBERS

PARTS LIST (Cont.)

REF. DESCRIPTION	TYPE	B2G/B2GE PART NO.	B4G PART NO.	B1H/B1HE PART NO.	B2H/B2HE PART NO.	B1J/B1JE PART NO.	B2J/B2JE PART NO.
0100 DRIVE ADAPTOR	CD/SS	CC B1F0100	CC B1H0100	CC B1H0100	CC B1H0100	CC B1H0100	CC B1H0100
0900 PACKING GLAND	CD/SS	SC A1F0910	SC A1H0910	SC A1H0910	SC A1H0910	SC A1H0910	SC A1H0910
1000 STUFFING BOX	CD SS	CC A1F1010 SC A1F1010	CC A1H1010 SC A1H1010	CC A1H1010 SC A1H1010	CC A1H1010 SC A1H1010	CC A1H1010 SC A1H1010	CC A1H1010 SC A1H1010
1000 SEAL HOUSING	* ** CD/SS	SC A1F1011 4240835007	SC A1H1011 4240836007	SC A1H1011 4240836007	SC A1H1011 4240836007	SC A1H1011 4240836007	SC A1F1011 4240835007
1100 SUCTION CHAMBER	CD SS	CC A1G1110 SC A1G1110	CC A1H1110 SC A1H1110	CC A1H1110 SC A1H1110	CC A1H1110 SC A1H1110	CC A1H1110 SC A1H1110	CC A1H1110 SC A1H1110
1200 STATOR GASKET	Q/R F B	GG A1G1200 GF A1G1200 GB A1G1200	GG A1G1200 GF A1G1200 GB A1G1200	GG A1H1200 GF A1H1200 GB A1H1200	GG A1H1200 GF A1H1200 GB A1H1200	GG A1H1200 GF A1H1200 GB A1H1200	GG A1H1200 GF A1H1200 GB A1H1200
1210 STATOR ADAPTOR GASKET	Q/R F B		GG A1H1200 GF A1H1200 GB A1H1200				
1220 SUCTION CHAM. GASKET	Q/R F B	GG A1F1220 GF A1F1220 GB A1F1220	GG A1H1220 GF A1H1220 GB A1H1220	GG A1H1220 GF A1H1220 GB A1H1220	GG A1H1220 GF A1H1220 GB A1H1220	GG A1H1220 GF A1H1220 GB A1H1220	GG A1H1220 GF A1H1220 GB A1H1220
1240 INSPT. PLATE GSKT.	Q/R F BA	GG A1G1240 GF A1G1240 GB A1G1240	GG A1H1240 GF A1H1240 GB A1H1240	GG A1H1240 GF A1H1240 GB A1H1240	GG A1H1240 GF A1H1240 GB A1H1240	GG A1H1240 GF A1H1240 GB A1H1240	GG A1H1240 GF A1H1240 GB A1H1240
1400 DISCHARGE FLANGE	CD SS	MS A1G1410 SS A1G1410	MS A4G1410 SS A4G1410	MS A1H1410 SS A1H1410	MS A1H1410 SS A1H1410	MS A1H1410 SS A1H1410	MS A1H1410 SS A1H1410
1500 STATOR ADAPTOR	CD SS		MS A4G1510 SS A4G1510				
1600 LOCKING RING	CD/SS	MT B1F1600					
1700 STATOR SUPPORT	CD/SS	CC A1G1710	CC A4G1710	CC A1H1710	CC A1H1710	CC A1H1710	CC A1H1710
1800 CLAMP RING	CD/SS CD/SS	MS A1G1810	MS A4G1810 MS A4G1811	MS A1H1810	MS A1H1810	MS A1H1810	MS A1H1810
1900 INSPECTION PLATE	CD SS	MS A1G1900 SS A1G1900	MS A1H1900 SS A1H1900	MS A1H1900 SS A1H1900	MS A1H1900 SS A1H1900	MS A1H1900 SS A1H1900	MS A1H1900 SS A1H1900
2000 SHAFT PIN	CD/SS	4220489017	4220492017	4220492017	4220492017	4220492017	4220492017
5000 ROTOR	CD CD SS SS	TS A2G5000 TS A2GE5000 SS A2G5000 SS A2GE5000	TS A4G5000 SS A4G5000	TS A1H5000 TS A1H5000 SS A1H5000 SS A1HE5000	TS A2H5000 TS A2HE5000 SS A2H5000 SS A2H5000	TS A1J5000 TS A1JE5000 SS A1J5000 SS A1JE5000	TS A2J5000 TS A2JE5000 SS A2J5000 SS A2JE5000
6000 DRIVE SHAFT - KEY	CD SS	AS B1G6000 SS B1G6000					
6000 CC DRIVE SHAFT - PIN	CD SS	4250744001 4250744015	AS B1H6000 SS B1H6000	AS B1H6000 SS B1H6000	AS B1H6000 SS B1H6000	AS B1H6000 SS B1H6000	AS B1H6000 SS B1H6000
6100 RETAINING RING	CD/SS	ST A1G6100	ST A1H6100	ST A1H6100	ST A1H6100	ST A1H6100	ST A1H6100
6200 CONNECTING ROD	CD SS	AS A1G6200 SS A1G6200	AS A1H6200 SS A1H6200	AS A1H6200 SS A1H6200	AS A1H6200 SS A1H6200	AS A1H6200 SS A1H6200	AS A1H6200 SS A1H6200
6300 DRIVE PIN	CD/SS	TR A1G6300	TR A1H6300	TR A1H6300	TR A1H6300	TR A1H6300	TR A1H6300
6400 JOINT SEAL	Q/R F/B	RD A1G6400 RF A1G6400	RD A1H6400 RF A1H6400	RD A1H6400 RF A1H6400	RD A1H6400 RF A1H6400	RD A1H6400 RF A1H6400	RD A1H6400 RF A1H6400
6500 STATOR	Q Q R R F B B	RQ A2G6510 RQ A2GE6510 RR A2G6510 RR A2GE6510 RF A2G6510 RB A2G6510 RB A2GE6510	RQ A4G6510 RR A4G6510	RQ A1H6510 RQ A1HE6510 RR A1H6510 RR A1HE6510 RF A1H6510 RB A1H6510 RB A1HE6510	RQ A2H6510 RQ A2HE6510 RR A2H6510 RR A2HE6510 RF A2H6510 RB A2H6510 RB A2HE6510	RQ A1J6510 RQ A1JE6510 RR A1J6510 RR A1JE6510 RF A1J6510 RB A1J6510 RB A1JE6510	RQ A2J6510 RQ A2JE6510 RR A2J6510 RR A2JE6510 RF A2J6510 RB A2J6510 RB A2JE6510
6800 SLINGER RING - KEY	CD/SS	RZ A1F6800					
6800 SLINGER/PIN RETNR - 2 PC/CC	CD/SS	4230530000	4230531000	4230531000	4230531000	4230531000	4230531000
6850 LANTERN RING	CD/SS	GR A1F6850	GR A1H6850	GR A1H6850	GR A1H6850	GR A1H6850	GR A1H6850
6900 PACKING	STD. PTFE	PC A1F6901 3403655003	PC A1H6901 3403655004	PC A1H6901 3403655004	PC A1H6901 3403655004	PC A1H6901 3403655004	PC A1H6901 3403655004
7000 NAME PLATE	CD/SS	GA B2A7000	GA B2A7000	GA B2A7000	GA B2A7000	GA B2A7000	GA B2A7000
K O-RING	Q/R F/B	CA197 CF197	CA228 CF228	CA228 CF228	CA228 CF228	CA228 CF228	CA228 CF228
J SNAP RING	CD SS	EB045 EB545	EB049 EB549	EB049 EB549	EB049 EB549	EB049 EB549	EB049 EB549
R STATOR RING	CD/SS	EC060	EC065	EC065	EC065	EC065	EC065

*FRICTION DRIVE SEAL, TYPE 43 OR EQUAL

**POSITIVE DRIVE SEAL, TYPE 680 OR EQUAL

NOTE: CONTACT FACTORY FOR REPLACEMENT MECHANICAL SEAL PART NUMBERS

REF. DESCRIPTION	TYPE	B1K/B1KE PART NO.	B2K/B2KE PART NO.	B1L PART NO.
0100 DRIVE ADAPTOR	CD/SS	CC B1H0100	CC B1H0100	CC B1H0100
0900 PACKING GLAND	CD/SS	SC A1H0910	SC A1H0910	SC A1H0910
1000 STUFFING BOX	CD SS	CC A1H1010 SC A1H1010	CC A1H1010 SC A1H1010	CC A1H1010 SC A1H1010
1000 SEAL HOUSING	* ** CD/SS	SC A1H1011 4240836007	SC A1H1011 4240836007	SC A1H1011 4240836007
1100 SUCTION CHAMBER	CD SS	CC A1H1110 SC A1H1110	CC A1H1110 SC A1H1110	CC A1H1110 SC A1H1110
1200 STATOR GASKET	Q/R F B	GG A1H1200 GF A1H1200 GB A1H1200	GG A1H1200 GF A1H1200 GB A1H1200	GG A1H1200 GF A1H1200 GB A1H1200
1210 STATOR ADAPTOR GASKET	Q/R F B			
1220 SUCTION CHAM. GASKET	Q/R F B	GG A1H1220 GF A1H1220 GB A1H1220	GG A1H1220 GF A1H1220 GB A1H1220	GG A1H1220 GF A1H1220 GB A1H1220
1240 INSPT. PLATE GSKT.	Q/R F BA	GG A1H1240 GF A1H1240 GB A1H1240	GG A1H1240 GF A1H1240 GB A1H1240	GG A1H1240 GF A1H1240 GB A1H1240
1400 DISCHARGE FLANGE	CD SS	MS A1H1410 SS A1H1410	MS A1H1410 SS A1H1410	MS A1H1410 SS A1H1410
1500 STATOR ADAPTOR	CD SS			
1600 LOCKING RING	CD/SS			
1700 STATOR SUPPORT	CD/SS	CC A1H1710	CC A1H1710	CC A1H1710
1800 CLAMP RING	CD/SS CD/SS	MS A1H1810	MS A1H1810	MS A1H1810
1900 INSPECTION PLATE	CD SS	MS A1H1900 SS A1H1900	MS A1H1900 SS A1H1900	MS A1H1900 SS A1H1900
2000 SHAFT PIN	CD/SS	4220492017	4220492017	4220492017
5000 ROTOR	CD CD SS SS	TS A1K5000 TS A1K5000 SS A1K5000 SS A1KE5000	TS A2K5000 TS A2KE5000 SS A2K5000 SS A2K5000	TS A1L5000 TS A1LE5000 SS A1L5000 SS A1LE5000
6000 DRIVE SHAFT - KEY	CD SS			
6000 CC DRIVE SHAFT - PIN	CD SS	AS B1H6000 SS B1H6000	AS B1H6000 SS B1H6000	AS B1H6000 SS B1H6000
6100 RETAINING RING	CD/SS	ST A1H6100	ST A1H6100	ST A1H6100
6200 CONNECTING ROD	CD SS	AS A1H6200 SS A1H6200	AS A1H6200 SS A1H6200	AS A1H6200 SS A1H6200
6300 DRIVE PIN	CD/SS	TR A1H6300	TR A1H6300	TR A1H6300
6400 JOINT SEAL	Q/R F/B	RD A1H6400 RF A1H6400	RD A1H6400 RF A1H6400	RD A1H6400 RF A1H6400
6500 STATOR	Q Q R R F B B	RQ A1K6510 RQ A1KE6510 RR A1K6510 RR A1KE6510 RF A1K6510 RB A1K6510 RB A1KE6510	RQ A2K6510 RQ A2KE6510 RR A2K6510 RR A2KE6510 RF A2K6510 RB A2K6510 RB A2KE6510	RQ A1L6510 RR A1L6510 RF A1L6510 RB A1L6510
6800 SLINGER RING - KEY	CD/SS			
6800 SLINGER/PIN RETNR - 2 PC/CC	CD/SS	4230531000	4230531000	4230531000
6850 LANTERN RING	CD/SS	GR A1H6850	GR A1H6850	GR A1H6850
6900 PACKING	STD. PTFE	PC A1H6901 3403655004	PC A1H6901 3403655004	PC A1H6901 3403655004
7000 NAME PLATE	CD/SS	GA B2A7000	GA B2A7000	GA B2A7000
K O-RING	Q/R F/B	CA228 CF228	CA228 CF228	CA228 CF228
J SNAP RING	CD SS	EB049 EB549	EB049 EB549	EB049 EB549
R STATOR RING	CD/SS	EC065	EC065	EC065

*FRICTION DRIVE SEAL, TYPE 43 OR EQUAL

**POSITIVE DRIVE SEAL, TYPE 680 OR EQUAL

NOTE: CONTACT FACTORY FOR REPLACEMENT MECHANICAL SEAL PART NUMBERS

PARTS LIST (Cont.)

REF. DESCRIPTION	TYPE	C1E PART NO.	C2E PART NO.	C1F/C1FE PART NO.	C2F/C2FE PART NO.	C1G/C1GE PART NO.
0100 BEARING HOUSING	CD/SS	CC A1D0110	CC A1D0110	CC A1F0110	CC A1F0110	CC A1F0110
0300 BEARING COVER	CD/SS	CC A1D0300	CC A1D0300	CC A1F0300	CC A1F0300	CC A1F0300
0500 GREASE RETAINER	CD/SS	MA A1D0500	MS A1D0500	MS A1F0500	MS A1F0500	MS A1F0500
0700 GREASE SEAL HSG.	CD/SS	MS A1D0700	MS A1D0700	MS A1F0700	MS A1F0700	MS A1F0700
0900 PACKING GLAND	CD/SS	SC A1D0910	SC A1D0910	SC A1F0910	SC A1F0910	SC A1F0910
1000 STUFFING BOX	CD SS	CC A1D1010 SC A1D1010	CC A1D1010 SC A1D1010	CC A1F1010 SC A1F1010	CC A1F1010 SC A1F1010	CC A1F1010 SC A1F1010
1000 SEAL HOUSING	* ** CD/SS CD/SS	SC A1D1011 4240834007	SC A1D1011 4240834007	SC A1F1011 4240835007	SC A1F1011 4240835007	SC A1F1011 4240835007
1100 SUCTION CHAMBER	CD SS	CC C1E1110 SC C1E1110	CC C1E1110 SC C1E1110	CC C1F1110 SC C1F1110	CC C1F1110 SC C1F1110	CC C1G1110 SC C1G1110
1200 STATOR GASKET	Q/R F B	GG A1E1200 GF A1E1200 GB A1E1200	GG A1E1200 GF A1E1200 GB A1E1200	GG A1F1200 GF A1F1200 GB A1F1200	GG A1F1200 GF A1F1200 GB A1F1200	GG A1G1200 GF A1G1200 GB A1G1200
1220 SUCTION CHAM. GASKET	Q/R F B	GG A1D1220 GF A1D1220 GB A1D1220	GG A1D1220 GF A1D1220 GB A1D1220	GG A1F1220 GF A1F1220 GB A1F1220	GG A1F1220 GF A1F1220 GB A1F1220	GG A1F1220 GF A1F1220 GB A1F1220
1400 DISCHARGE FLANGE	CD SS	MS A1E1410 SS A1E1410	MS A1E1410 SS A1E1410	MS A1F1410 SS A1F1410	MS A1F1410 SS A1F1410	MS A1G1410 SS A1G1410
1700 STATOR SUPPORT	CD/SS	CC A1E1710	CC A1E1710	CC A1F1710	CC A1F1710	CC A1G1710
1800 CLAMP RING	CD/SS	MS A1E1810	MS A1E1810	MS A1F1810	MS A1F1810	MS A1G1810
2000 SHAFT PIN	CD/SS	4220488017	4220488017	4220489017	4220489017	4220489017
2100 INTERMEDIATE SHAFT	CD SS	4250395001 4250395017	4250395001 4250395017	4250396001 4250396017	4250396001 4250396017	4250397001 4250397017
2200 SEAL O-RING	Q/R F B	3207902210 3207905210 3207904210	3207902210 3207905210 3207904210	3207902216 3207905216 3207904216	3207902216 3207905216 3207904216	3207902216 3207905216 3207904216
5000 ROTOR	CD CD SS SS	TS A1E5000 SS A1E5000	TS A2E5000 SS A2E5000	TS A1F5000 TS A1FE5000 SS A1F5000 SS A1FE5000	TS A2F5000 TS A2FE5000 SS A2F5000 SS A2FE5000	TS A1G5000 TS A1GE5000 SS A1G5000 SS A1GE5000
6000 DRIVE SHAFT	CD SS	AS A1E6000 SS A1E6000	AS A1E6000 SS A1E6000	AS A1F6000 SS A1F6000	AS A1F6000 SS A1F6000	AS A1G6000 SS A1G6000
6000 DRIVE SHAFT (2-PIECE OPTION)	CD SS	4250379001 4250379015	4250379001 4250379015	4250380001 4250380015	4250380001 4250380015	4250380001 4250380015
6100 RETAINING RING	CD/SS	ST A1E6100	ST A1E6100	ST A1F6100	ST A1F6100	ST A1G6100
6200 CONNECTING ROD	CD SS	AS C1E6200 SS C1E6200	AS C1E6200 SS C1E6200	AS C1F6200 SS C1F6200	AS C1F6200 SS C1F6200	AS C1G6200 SS C1G6200
6300 DRIVE PIN	CD/SS	TR A1E6300	TR A1E6300	TR A1F6300	TR A1F6300	TR A1G6300
6400 JOINT SEAL	Q/R F/B	RD A1E6400 RF A1E6400	RD A1E6400 RF A1E6400	RD A1F6400 RF A1F6400	RD A1F6400 RF A1F6400	RD A1G6400 RF A1G6400
6500 STATOR	Q Q R R F B B	RQ A1E6510 RR A1E6510 RF A1E6510 RB A1E6510	RQ A2E6510 RR A2E6510 RF A2E6510 RB A2E6510	RQ A1F6510 RQ A1FE6510 RR A1F6510 RR A1FE6510 RF A1F6510 RB A1F6510 RB A1FE6510	RQ A2F6510 RQ A2FE6510 RR A2F6510 RR A2FE6510 RF A2F6510 RB A2F6510 RB A2FE6510	RQ A1G6510 RQ A1GE6510 RR A1G6510 RR A1GE6510 RF A1G6510 RF A1GE6510 RB A1G6510 RB A1GE6510
6700 BEARING SHIMS	CD/SS	GP A1D6700	GP A1D6700	GP A1F6700	GP A1F6700	GP A1F6700
6800 SLINGER RING	CD/SS	RZ A1D6800	RZ A1D6800	RZ A1F6800	RZ A1F6800	RZ A1F6800
6800 SLINGER/PIN RETNR. (2-PIECE OPTION)	CD/SS	4230529000	4230530000	4230530000	4230530000	4230530000
6850 LANTERN RING	CD/SS	GR A1D6850	GR A1D6850	GR A1F6850	GR A1F6850	GR A1F6850
6900 PACKING	STD. PTFE	PC A1D6901 3403655002	PC A1D6901 3403655002	PC A1F6901 3403655003	PC A1F6901 3403655003	PC A1F6901 3403655003
7000 NAME PLATE	CD/SS	GA A2A7000	GA A2A7000	GA A1F7000	GA A1F7000	GA A1F7000
K O-RING	Q/R F/B	CA175 CF175	CA175 CF175	CA188 CF188	CA188 CF188	CA197 CF197
J SNAP RING	CD SS	EB027 EB527	EB027 EB527	EB036 EB536	EB036 EB536	EB045 EB545
R STATOR RING	CD/SS	EC046	EC046	EC055	EC055	EC060

*FRICTION DRIVE SEAL, TYPE 43 OR EQUAL

**POSITIVE DRIVE SEAL, TYPE 680 OR EQUAL

NOTE: CONTACT FACTORY FOR REPLACEMENT MECHANICAL SEAL PART NUMBERS

PARTS LIST (Cont.)

REF. DESCRIPTION	TYPE	C2G/C2GE PART NO.	C1H/C1HE PART NO.	C2H/C2HE PART NO.	C1J/C1JE PART NO.	C2J/C2JE PART NO.	C1K/C1KE PART NO.
0100 BEARING HOUSING	CD/SS	CC A1F0110	CC A1H0110	CC A1H0110	CC A1H0110	CC A1H0110	CC A1H0110
0300 BEARING COVER	CD/SS	CC A1F0300	CC A1H0300	CC A1H0300	CC A1H0300	CC A1H0300	CC A1H0300
0500 GREASE RETAINER	CD/SS	MS A1F0500	MS A1H0500	MS A1H0500	MS A1H0500	MS A1H0500	MS A1H0500
0700 GREASE SEAL HSG.	CD/SS	MS A1F0700	MS A1H0700	MS A1H0700	MS A1H0700	MS A1H0700	MS A1H0700
0900 PACKING GLAND	CD/SS	SC A1F0910	SC A1H0910	SC A1H0910	SC A1H0910	SC A1H0910	SC A1H0910
1000 STUFFING BOX	CD SS	CC A1F1010 SC A1F1010	CC A1H1010 SC A1H1010	CC A1H1010 SC A1H1010	CC A1H1010 SC A1H1010	CC A1H1010 SC A1H1010	CC A1H1010 SC A1H1010
1000 SEAL HOUSING	* **	CD/SS CD/SS	SC A1F1011 4240835007	SC A1H1011 4240836007	SC A1H1011 4240836007	SC A1H1011 4240836007	SC A1H1011 4240836007
1100 SUCTION CHAMBER	CD SS	CC C1G1110 SC C1G1110	CC C1H1110 SC C1H1110	CC C1H1110 SC C1H1110	CC C1H1110 SC C1H1110	CC C1H1110 SC C1H1110	CC C1H1110 SC C1H1110
1200 STATOR GASKET	Q/R F B	GG A1G1200 GF A1G1200 GB A1G1200	GG A1H1200 GF A1H1200 GB A1H1200	GG A1H1200 GF A1H1200 GB A1H1200	GG A1H1200 GF A1H1200 GB A1H1200	GG A1H1200 GF A1H1200 GB A1H1200	GG A1H1200 GF A1H1200 GB A1H1200
1220 SUCTION CHAM. GASKET	Q/R F B	GG A1F1220 GF A1F1220 GB A1F1220	GG A1H1220 GF A1H1220 GB A1H1220	GG A1H1220 GF A1H1220 GB A1H1220	GG A1H1220 GF A1H1220 GB A1H1220	GG A1H1220 GF A1H1220 GB A1H1220	GG A1H1220 GF A1H1220 GB A1H1220
1400 DISCHARGE FLANGE	CD SS	MS A1G1410 SS A1G1410	MS A1H1410 SS A1H1410	MS A1H1410 SS A1H1410	MS A1H1410 SS A1H1410	MS A1H1410 SS A1H1410	MS A1H1410 SS A1H1410
1700 STATOR SUPPORT	CD/SS	CC A1G1710	CC A1H1710	CC A1H1710	CC A1H1710	CC A1H1710	CC A1H1710
1800 CLAMP RING	CD/SS	MS A1G1810	MS A1H1810	MS A1H1810	MS A1H1810	MS A1H1810	MS A1H1810
2000 SHAFT PIN	CD/SS	4220489017	4220492017	4220492017	4220492017	4220492017	4220492017
2100 INTERMEDIATE SHAFT	CD SS	4250397001 4250397017	4250398001 4250398017	4250398001 4250398017	4250398001 4250398017	4250398001 4250398017	4250398001 4250398017
2200 SEAL RING	Q/R F B	3207902216 3207905216 3207904216	3207902223 3207905223 3207904223	3207902223 3207905223 3207904223	3207902223 3207905223 3207904223	3207902223 3207905223 3207904223	3207902223 3207905223 3207904223
5000 ROTOR	CD CD SS SS	TS A2G5000 TS A2GE5000 SS A2G5000 SS A2GE5000	TS A1H5000 TS A1HE5000 SS A1H5000 SS A1HE5000	TS A2H5000 TS A2HE5000 SS A2H5000 SS A2HE5000	TS A1J5000 TS A1JE5000 SS A1J5000 SS A1JE5000	TS A2J5000 TS A2JE5000 SS A2J5000 SS A2JE5000	TS A1K5000 TS A1KE5000 SS A1K5000 SS A1KE5000
6000 DRIVE SHAFT	CD SS	AS A1G6000 SS A1G6000	AS A1H6000 SS A1H6000	AS A1H6000 SS A1H6000	AS A1H6000 SS A1H6000	AS A1H6000 SS A1H6000	AS A1H6000 SS A1H6000
6000 DRIVE SHAFT (2-PIECE OPTION)	CD SS	4250380001 4250380015	4250381001 4250381015	4250381001 4250381015	4250381001 4250381015	4250381001 4250381015	4250381001 4250381015
6100 RETAINING RING	CD/SS	ST A1G6100	ST A1H6100	ST A1H6100	ST A1H6100	ST A1H6100	ST A1H6100
6200 CONNECTING ROD	CD SS	AS C1G6200 SS C1G6200	AS C1H6200 SS C1H6200	AS C1H6200 SS C1H6200	AS C1H6200 SS C1H6200	AS C1H6200 SS C1H6200	AS C1H6200 SS C1H6200
6300 DRIVE PIN	CD/SS	TR A1G6300	TR A1H6300	TR A1H6300	TR A1H6300	TR A1H6300	TR A1H6300
6400 JOINT SEAL	Q/R F/B	RD A1G6400 RF A1G6400	RD A1H6400 RF A1H6400	RD A1H6400 RF A1H6400	RD A1H6400 RF A1H6400	RD A1H6400 RF A1H6400	RD A1H6400 RF A1H6400
6500 STATOR	Q Q R R F B B	RQ A2G6510 RQ A2GE6510 RR A2G6510 RR A2GE6510 RF A2G6510 RB A2G6510 RB A2GE6510	RQ A1H6510 RQ A1HE6510 RR A1H6510 RR A1HE6510 RF A1H6510 RB A1H6510 RB A1HE6510	RQ A2H6510 RQ A2HE6510 RR A2H6510 RR A2HE6510 RF A2H6510 RB A2H6510 RB A2HE6510	RQ A1J6510 RQ A1JE6510 RR A1J6510 RR A1JE6510 RF A1J6510 RB A1J6510 RB A1JE6510	RQ A2J6510 RQ A2JE6510 RR A2J6510 RR A2JE6510 RF A2J6510 RB A2J6510 RB A2JE6510	RQ A1K6510 RQ A1KE6510 RR A1K6510 RR A1KE6510 RF A1K6510 RB A1K6510 RB A1KE6510
6700 BEARING SHIMS	CD/SS	GP A1F6700	GP A1H6700	GP A1H6700	GP A1H6700	GP A1H6700	GP A1H6700
6800 SLINGER RING	CD/SS	RZ A1F6800	RZ A1H6800	RZ A1H6800	RZ A1H6800	RZ A1H6800	RZ A1H6800
6800 SLINGER/PIN RETNR (2-PIECE OPTION)	CD/SS	4230530000	4230531000	4230531000	4230531000	4230531000	4230531000
6850 LANTERN RING	CD/SS	GR A1F6850	GR A1H6850	GR A1H6850	GR A1H6850	GR A1H6850	GR A1H6850
6900 PACKING	STD. PTFE	PC A1F6901 3403655003	PC A1H6901 3403655004	PC A1H6901 3403655004	PC A1H6901 3403655004	PC A1H6901 3403655004	PC A1H6901 3403655004
7000 NAME PLATE	CD/SS	GA A1F7000	GA A1H7000	GA A1H7000	GA A1H7000	GA A1H7000	GA A1H7000
K O-RING	Q/R F/B	CA197 CF197	CA228 CF228	CA228 CF228	CA228 CF228	CA228 CF228	CA228 CF228
J SNAP RING	CD SS	EB045 EB545	EB049 EB549	EB049 EB549	EB049 EB549	EB049 EB549	EB049 EB549
R STATOR RING	CD/SS	EC060	EC065	EC065	EC065	EC065	EC065

*FRICTION DRIVE SEAL, TYPE 43 OR EQUAL

**POSITIVE DRIVE SEAL, TYPE 680 OR EQUAL

NOTE: CONTACT FACTORY FOR REPLACEMENT MECHANICAL SEAL PART NUMBERS

PARTS LIST (Cont.)

REF. DESCRIPTION	TYPE	D4B PART NO.	D4C PART NO.	D4D PART NO.	D4E PART NO.	D4F PART NO.	D4G PART NO.	D4H PART NO.
0100 BEARING HOUSING	CD/SS	CC A2A0110	CC A2A0110	CC A1D0110	CC A1D0110	CC A1F0110	CC A1F0110	CC A1H0110
0300 BEARING COVER	CD/SS			CC A1D0300	CC A1D0300	CC A1F0300	CC A1F0300	CC A1H0300
0500 GREASE RETAINER	CD/SS			MS A1D0500	MS A1D0500	MS A1F0500	MS A1F0500	MS A1H0500
0700 GREASE SEAL HSG.	CD/SS			MS A1D0700	MS A1D0700	MS A1F0700	MS A1F0700	MS A1H0700
0900 PACKING GLAND	CD/SS	SC A2A0910	SC A2A0910	SC A1D0910	SC A1D0910	SC A1F0910	SC A1F0910	SC A1H0910
1000 STUFFING BOX	CD SS	CC A2A1010 SC A2A1010	CC A1A1010 SC A1A1010	CC A1D1010 SC A1D1010	CC A1E1010 SC A1E1010	CC A1F1010 SC A1F1010	CC A1G1010 SC A1G1010	CC A1H1010 SC A1H1010
1000 SEAL HOUSING	CD/SS CD/SS	SC A2A1011 4240833007	SC A2A1011 4240833007	SC A1D1011 4240834007	SC A1D1011 4240834007	SC A1F1011 4240835007	SC A1F1011 4240835007	SC A1H1011 4240836007
1100 SEAL CHAMBER	CD SS	CC A1B1110 SC A1B1110	CC A1C1110 SC A1C1110	CC A1D1110 SC A1D1110	CC A1E1110 SC A1E1110	CC A1F1110 SC A1F1110	CC A1G1110 SC A1G1110	CC A1H1110 SC A1H1110
1200 STATOR GASKET	Q/R F B	GG A1B1200 GF A1B1200 GB A1B1200	GG A1C1200 GF A1C1200 GB A1C1200	GG A1D1200 GF A1D1200 GB A1D1200	GG A1E1200 GF A1E1200 GB A1E1200	GG A1F1200 GF A1F1200 GB A1F1200	GG A1G1200 GF A1G1200 GB A1G1200	GG A1H1200 GF A1H1200 GB A1H1200
1220 SUCTION CHAM. GASKET	Q/R F B	GG A2A1220 GF A2A1220 GB A2A1220	GG A2A1220 GF A2A1220 GB A2A1220	GG A1D1220 GF A1D1220 GB A1D1220	GG A1D1220 GF A1D1220 GB A1D1220	GG A1F1220 GF A1F1220 GB A1F1220	GG A1F1220 GF A1F1220 GB A1F1220	GG A1H1220 GF A1H1220 GB A1H1220
1240 INSP. PLATE GSKT.	Q/R F B				GG A1E1240 GF A1E1240 GB A1E1240	GG A1F1240 GF A1F1240 GB A1F1240	GG A1G1240 GF A1G1240 GB A1G1240	GG A1H1240 GF A1H1240 GB A1H1240
1400 DISCHARGE FLANGE	CD SS	MS A1B1410 SS A1B1410	MS A1C1410 SS A1C1410	MS A1D1410 SS A1D1410	MS A1E1410 SS A1E1410	MS A1F1410 SS A1F1410	MS A1G1410 SS A1G1410	MS A1H1410 SS A1H1410
1700 STATOR SUPPORT	CD/SS	MS A2A1710	MS A1C1710	CC A1D1710	CC A1E1710	CC A1F1710	CC A1G1710	CC A1H1710
1800 CLAMP RING	CD/SS	MS A1B1810	MS A1C1810	MS A1D1810	MS A1E1810	MS A1F1810	MS A1G1810	MS A1H1810
1900 INSPECTION PLATE	CD SS				MS A1E1900 SS A1E1900	MS A1F1900 SS A1F1900	MS A1G1900 SS A1G1900	MS A1H1900 SS A1H1900
2000 SHAFT PIN	CD/SS	4220487017	4220487017	4220488017	4220488017	4220489017	4220489017	4220489017
2100 INTERMEDIATE SHAFT	CD SS	4250392001 4250392017	4250393001 4250393017	4250394001 4250394017	4250395001 4250395017	4250396001 4250396017	4250397001 4250397017	4250398001 4250398017
2200 SEAL RING	Q/R F B	3207902206 3207905206 3207904206	3207902206 3207905206 3207904206	3207902210 3207905210 3207904210	3207902210 3207905210 3207904210	3207902216 3207905216 3207904216	3207902216 3207905216 3207904216	3207902223 3207905223 3207904223
5000 ROTOR	CD SS	TS D4B5000 SS D4B5000	TS D4C5000 SS D4C5000	TS D4D5000 SS D4D5000	TS D4E5000 SS D4E5000	TS D4F5000 SS D4F5000	TS D4G5000 SS D4G5000	TS D4H5000 SS D4H5000
6000 DRIVE SHAFT	CD SS	AS A2A6000 SS A2A6000	AS A1C6000 SS A1C6000	AS A1D6000 SS A1D6000	AS A1E6000 SS A1E6000	AS A1F6000 SS A1F6000	AS A1G6000 SS A1G6000	AS A1H6000 SS A1H6000
6000 DRIVE SHAFT (2-PIECE OPTION)	CD SS	4250378001 4250378015	4250378001 4250378015	4250379001 4250379015	4250379001 4250379015	4250380001 4250380015	4250380001 4250380015	4250381001 4250381015
6100 RETAINING RING	CD/SS	ST A2A6100	ST A1C6100	ST A1D6100	ST A1E6100	ST A1F6100	ST A1G6100	ST A1H6100
6200 CONNECTING ROD	CD SS	AS A2A6200 AS A2A6200	AS A1C6200 AS A1C6200	AS A1D6200 AS A1D6200	AS A1E6200 SS A1E6200	AS A1F6200 SS A1F6200	AS A1G6200 SS A1G6200	AS A1H6200 SS A1H6200
6300 DRIVE PIN	CD/SS	TR A2A6300	TR A1C6300	TR A1D6300	TR A1E6300	TR A1F6300	TR A1G6300	TR A1H6300
6400 JOINT SEAL	Q/R F/B	RD A2A6400 RF A2A6400	RD A1C6400 RF A1C6400	RD A1D6400 RF A1D6400	RD A1E6400 RF A1E6400	RD A1F6400 RF A1F6400	RD A1G6400 RF A1G6400	RD A1H6400 RF A1H6400
6500 STATOR	Q R F B	RQ A4B6510 RR A4B6510 RF A4B6510 RB A4B6510	RQ A4C6510 RR A4C6510 RF A4C6510 RB A4C6510	RQ A4D6510 RR A4D6510 RF A4D6510 RB A4D6510	RQ A4E6510 RR A4E6510 RF A4E6510 RB A4E6510	RQ A4F6510 RR A4F6510 RF A4F6510 RB A4F6510	RQ A4G6510 RR A4G6510 RF A4G6510 RB A4G6510	RQ A4H6510 RR A4H6510 RF A4H6510 RB A4H6510
6700 BEARING SHIMS	CD/SS			GP A1D6700	GP A1D6700	GP A1F6700	GP A1F6700	GP A1H6700
6800 SLINGER RING	CD/SS	RZ A2A6800	RZ A2A6800	RZ A1D6800	RZ A1D6800	RZ A1F6800	RZ A1F6800	RZ A1H6800
6800 SLINGER/PIN RETNR (2-PIECE OPTION)	CD/SS	4230528000	4230528000	4230529000	4230529000	4230530000	4230530000	4230531000
6850 LANTERN RING	CD/SS	GR A2A6850	GR A2A6850	GR A1D6850	GR A1D6850	GR A1F6850	GR A1F6850	GR A1H6850
6900 PACKING	STD. PTFE	PC A2A6901 3403655001	PC A2A6901 3403655001	PC A1D6901 3403655002	PC A1D6901 3403655002	PC A1F6901 3403655003	PC A1F6901 3403655003	PC A1H6901 3403655004
7000 NAME PLATE	CD/SS	GA A2A7000	GA A2A7000	GA A2A7000	GA A2A7000	GA A1F7000	GA A1F7000	GA A1F7000
K O-RING	Q/R F/B	CA137 CF137	CA141 CF141	CA145 CF145	CA175 CF175	CA197 CF188	CA197 CF197	CA228 CF228
J SNAP RING	CD SS	EB007 EB507	EB015 EB515	EB020 EB520	EB027 EB527	EB036 EB536	EB045 EB545	EB049 EB549
R STATOR RING	CD/SS	EC028	EC034	EC039	EC046	EC055	EC060	EC065

*FRICTION DRIVE SEAL, TYPE 43 OR EQUAL

**POSITIVE DRIVE SEAL, TYPE 680 OR EQUAL

NOTE: CONTACT FACTORY FOR REPLACEMENT MECHANICAL SEAL PART NUMBERS

PARTS LIST (Cont.)

REF. DESCRIPTION	TYPE	E4B PART NO.	E4C PART NO.	E4D PART NO.	E4E PART NO.
0100 DRIVE ADAPTOR	CD/SS	CC B2A0110	CC B2A0110	CC B1D0110	CC B1D0110
0900 PACKING GLAND	CD/SS	SC A2A0910	SC A2A0910	SC A1D0910	SC A1D0910
1000 STUFFING BOX	CD SS	CC A2A1010 SC A2A1010	CC A2A1010 SC A2A1010	CC A1D1010 SC A1D1010	CC A1D1010 SC A1D1010
1000 SEAL HOUSING	* ** CD/SS	SC A2A1011 4240833007	SC A2A1011 4240833007	SC A1D1011 4240834007	SC A1D1011 4240834007
1100 SUCTION CHAMBER STD.	CD SS	CC A1B1110 SC A1B1110	CC A1C1110 SC A1C1110	CC A1D1110 SC A1D1110	CC A1E1110 SC A1E1110
1200 STATOR GASKET	Q/R F B	GG A1B1200 GF A1B1200 GB 1B1200	GG A1C1200 GF A1C1200 GB A1C1200	GG A1D1200 GF A1D1200 GB A1D1200	GG A1E1200 GF A1E1200 GB A1E1200
1220 SUCTION CHAM. GASKET	Q/R F B	GG A2A1220 GF A2A1220 GB A2A1220	GG A2A1220 GF A2A1220 GB A2A1220	GG A1D1220 GF A1D1220 GB A1D1220	GG A1D1220 GF A1D1220 GB A1D1220
1240 INSPT. PLATE GSKT.	Q/R F B				GG A1E1240 GF A1E1240 GB A1E1240
1400 DISCHARGE FLANGE	CD SS	MS A1B1410 SS A1B1410	MS A1C1410 SS A1C1410	MS A1D1410 SS A1D1410	MS A1E1410 SS A1E1410
1600 LOCKING RING	CD/SS	MT B2A1600	MT B2A1600	MT B1D1600	MT B1D1600
1700 STATOR SUPPORT	CD/SS	MS A2A1710	MS A1C1710	CC A1D1710	CC A1E1710
1800 CLAMP RING	CD/SS	MS A1B1810	MS A1C1810	MS A1D1810	MS A1E1810
1900 INSPECTION PLATE	CD SS				MS A1E1900 SS A1E1900
2000 SHAFT PIN	CD/SS	4220487017	4220487017	4220488017	4220488017
5000 ROTOR	CD SS	TS D4B5000 SS D4B5000	TS D4C5000 SS D4C5000	TS D4D5000 SS D4D5000	TS D4E5000 SS D4E5000
6000 DRIVE SHAFT - KEY	CD SS	AS B2A6000 SS B2A6000	AS B1C6000 SS B1C6000	AS B1D6000 SS B1D6000	AS B1E6000 SS B1E6000
6000 CC DRIVE SHAFT - PIN	CD SS	4250778001 4250778015	4250779001 4250779015	4250780001 4250780015	4250760001 4250760015
6100 RETAINING RING	CD/SS	ST A2A6100	ST A1C6100	ST A1D6100	ST A1E6100
6200 CONNECTING ROD	CD SS	AS A2A6200 AS A2A6200	AS A1C6200 AS A1C6200	AS A1D6200 AS A1D6200	AS A1E6200 AS A1E6200
6300 DRIVE PIN	CD/SS	TR A2A6300	TR A1C6300	TR A1D6300	TR A1E6300
6400 JOINT SEAL	Q/R F/B	RD A2A6400 RF A2A6400	RD A1C6400 RF A1C6400	RD A1D6400 RF A1D6400	RD A1E6400 RF A1E6400
6500 STATOR	Q R F B	RQ A4B6510 RR A4B6510 RF A4B6510 RB A4B6510	RQ A4C6510 RR A4C6510 RF A4C6510 RB A4C6510	RQ A4D6510 RR A4D6510 RF A4D6510 RB A4D6510	RQ A4E6510 RR A4E6510 RF A4E6510 RB A4E6510
6800 SLINGER RING - KEY	CD/SS	RZ A2A6800	RZ A2A6800	RZ A1D6800	RZ A1D6800
6800 SLINGER/PIN RETNR - 2 PC/CC	CD/SS	4230528000	4230528000	4230529000	4230529000
6850 LANTERN RING	CD/SS	GR A2A6850	GR A2A6850	GR A1D6850	GR A1D6850
6900 PACKING	STD. PTFE	PC A2A6901 3403655001	PC A2A6901 3403655001	PC A1D6901 3403655002	PC A1D6901 3403655002
7000 NAME PLATE	CD/SS	GA B2A7000	GA B2A7000	GA B2A7000	GA B2A7000
K O-RING	Q/R F/B	CA137 CF137	CA141 CF141	CA145 CF145	CA175 CF175
J SNAP RING	CD SS	EB007 EB507	EB015 EB515	EB020 EB520	EB027 EB527
R STATOR RING	CD/SS	EC028	EC034	EC039	EC046

*FRICTION DRIVE SEAL, TYPE 43 OR EQUAL

**POSITIVE DRIVE SEAL, TYPE 680 OR EQUAL

NOTE: CONTACT FACTORY FOR REPLACEMENT MECHANICAL SEAL PART NUMBERS

4-49. TROUBLESHOOTING CHART

PUMP PROBLEMS

Pump does not rotate.

Pump does not discharge.

Discharge output low.

Discharge output fluctuates.

Pump drive overloaded.

Pump noisy.

Shaft seal leaks.

Stator wears too fast.

Rotor wears too fast.

PROBABLE CAUSE AND REMEDY

Incorrect power supply; drive not properly wired. *Check motor nameplate data; test voltage, phase, & frequency.*

Foreign matter in pump. *Remove foreign matter.*

If pump or stator is new, too much static friction. *Fill with liquid, and hand turn.*

Stator swells due to chemical attack. *Change stator material.*

Stator swells due to high liquid temp. *Reduce liquid temp. or use an undersized rotor.*

Blockage due to solids in liquid. *Decrease solids-to-liquid ratio.*

Liquid settles and hardens after pump shut down. *Clean and rinse pump after each use.*

Suction pipe not submerged. *Reposition suction pipe.*

Air in suction pipe. *Tighten connections to stop leaks.*

Pump speed too low. *Increase drive speed.*

Suction lift too high (cavitation). *Reduce suction losses; move pump to lower elevation; increase pipe size.*

Pump running dry; no prime. *Fill pump with liquid; relocate suction piping.*

Stator worn excessively. *Replace stator & inspect rotor.*

Rotor worn excessively. *Replace rotor.*

Wrong direction of rotation. *Reverse drive motor polarity.*

Discharge pressure too high. *Open discharge valve; reduce discharge pipe length; remove obstruction, increase pipe size.*

Suction pipe leaks. *Tighten pipe connections.*

Shaft packing leaks. *Tighten packing gland; replace packing; lubricate packing.*

Stator material brittle. *Replace stator.*

Pump speed too high. *Reduce drive speed.*

Liquid viscosity or specific gravity too high. *Measure and compare with specification.*

Packing too tight. *Loosen gland nuts, & lubricate packing.*

Bent drive shaft. *Replace drive shaft.*

Drive and pump misaligned. *Re-align drive and pump.*

Flexible drive coupling worn. *Repair or replace coupling.*

Drive shaft bearings worn. *Replace bearings.*

Incorrect packing. *Change packing material.*

Packing too loose. *Tighten gland nuts, & lubricate.*

Incorrect parts. *If pump has been rebuilt, check to verify original Moyno parts used.*

NOTE: If further troubleshooting procedural information is needed, please contact your authorized Moyno Pump distributor.

Your Authorized Service Distributor is: